

Copyright © 2016 Fisher & Arnold, Inc. All rights reserved.  
 Filename: W:\9275\Electrical\9275-E12-01ContPlan.dwg  
 Layout Name: Layout1  
 Plotted: Monday, August 01, 2016 - 10:29 am  
 By: B.S.

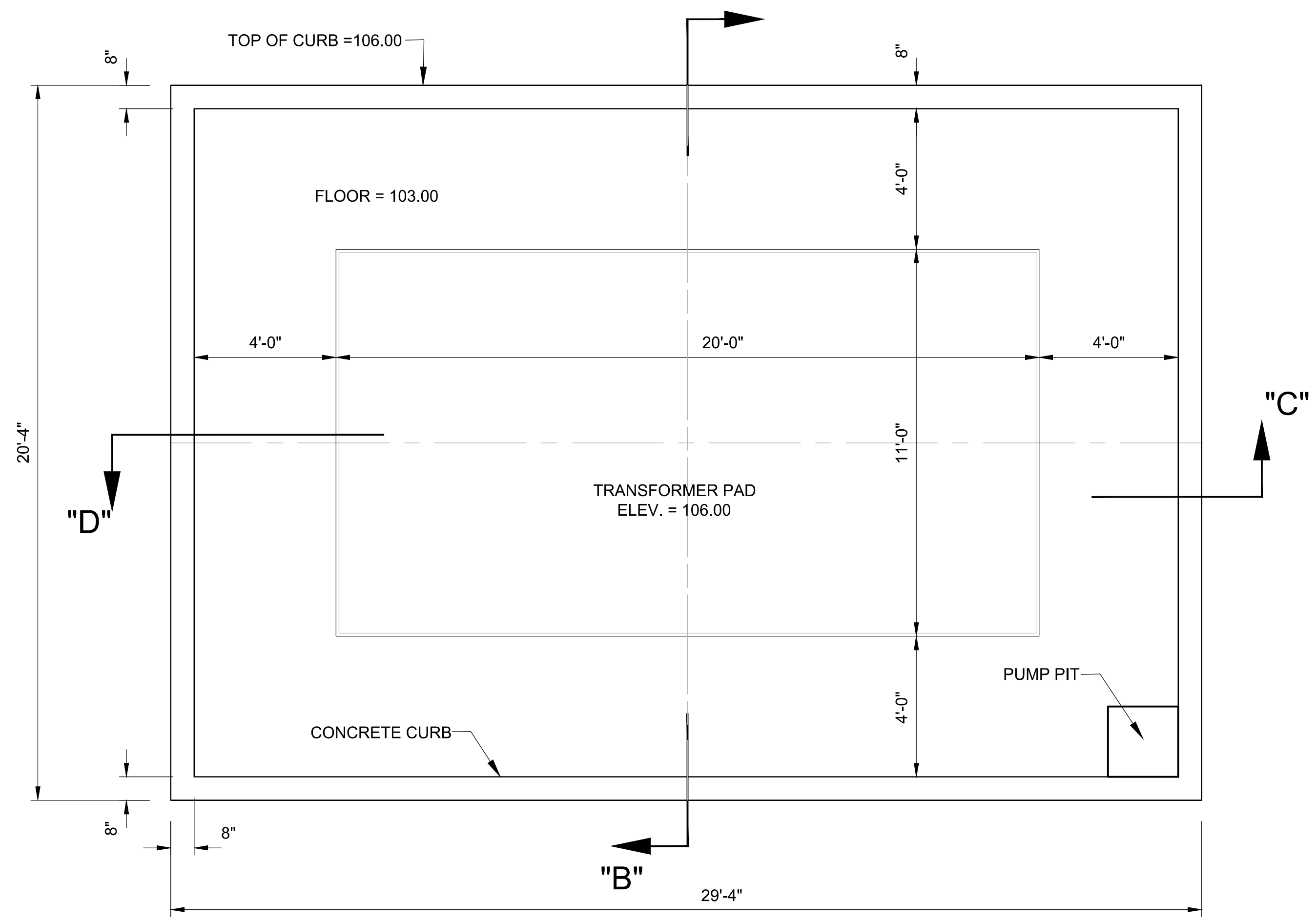

PLAN VIEW  
N.T.S.

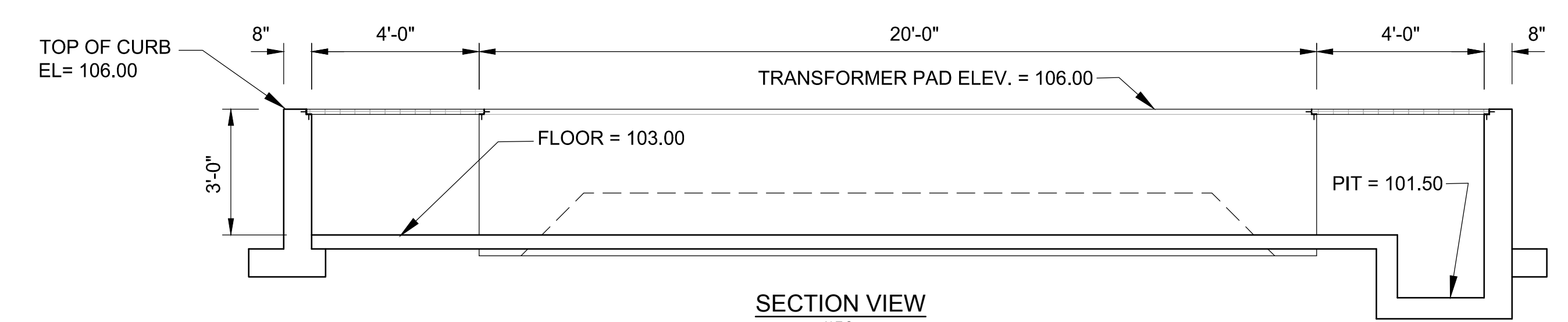

SECTION VIEW  
N.T.S.

NOTE:  
3" CLEARANCE TYPICAL BETWEEN REBARS AND CONCRETE SURFACES

NOTE:  
ENGINEER TO INSPECT PRIOR TO POURING CONCRETE AND PRIOR TO BACKFILL OF PIPE.

NOTE:  
ALL PVC TO BE SCHEDULE 80.

NOTE:  
MINIMUM 28 DAY COMPRESSIVE STRENGTH SHALL BE 4,000 PSI OR GREATER, IN ACCORDANCE WITH SECTION 03300.2.05.J, OF THE SPECIFICATIONS.

ELEVATIONS:  
ALL ELEVATIONS ARE ASSUMED AND SHOWN ONLY FOR DIMENSION PURPOSES.

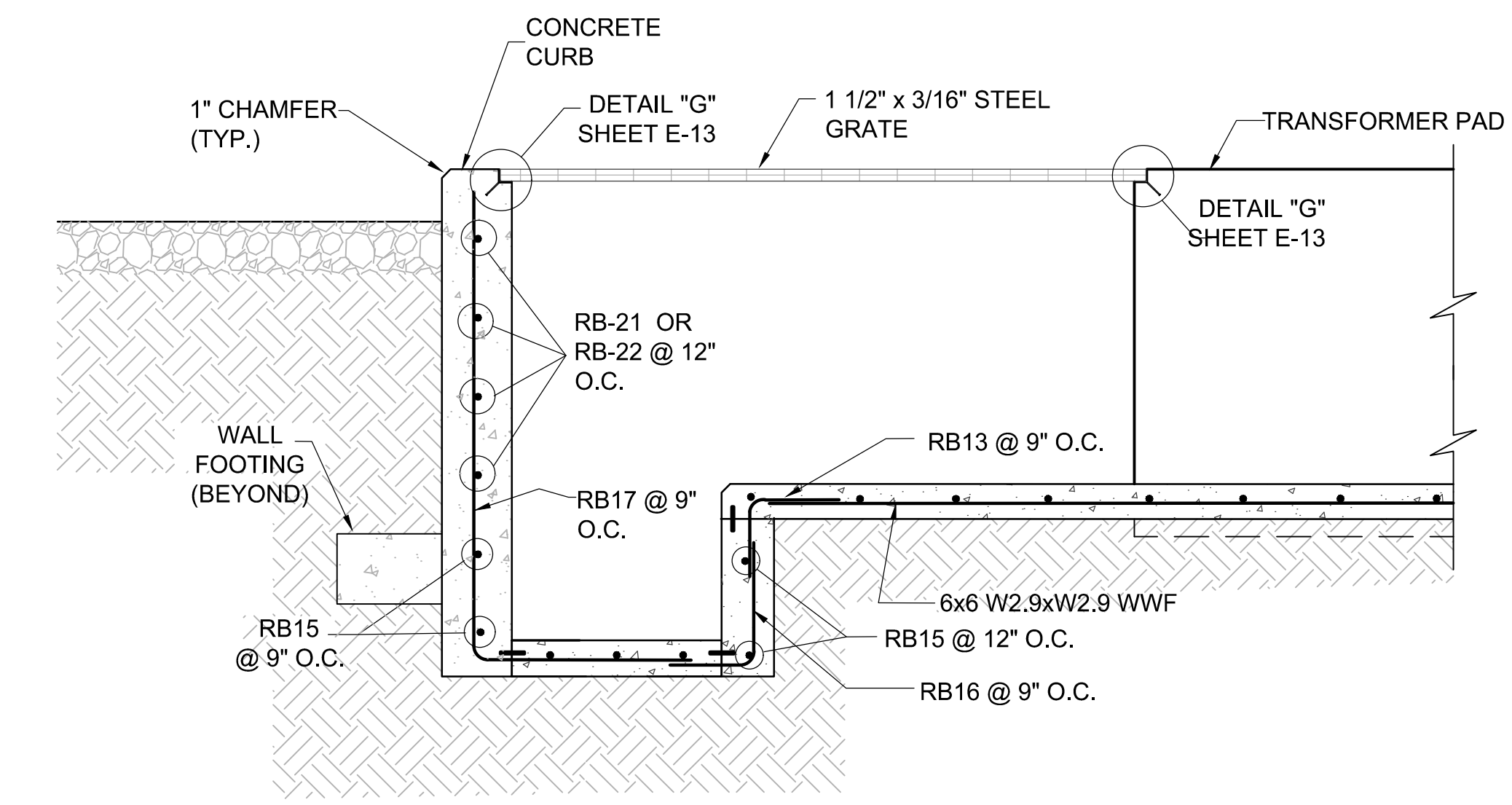
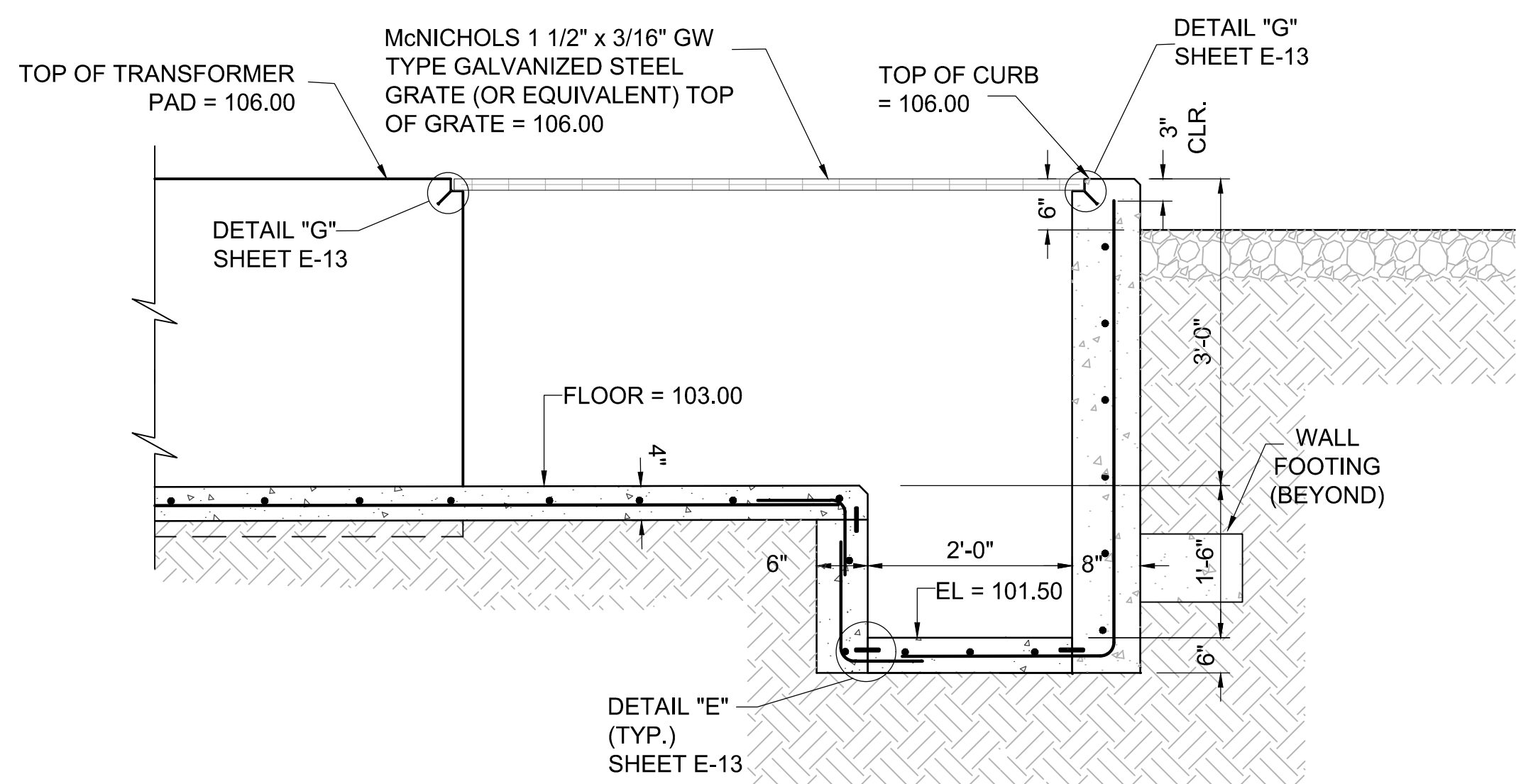

DRAIN BOX SECTIONS  
N.T.S.

**BID DOCUMENT**  
NOT FOR CONSTRUCTION

Rev.	Date	Revision Description

Seal

Issue Date: JULY 2016  
 Project No: H9275  
 Dwg File: 9275-E12-01ContPlan  
 Drawn By: B.S.  
 Checked By: G.H.M.

OIL CONTAINMENT  
PLAN & SECTIONS

Copyright 2016 Fisher & Arnold, Inc. All rights reserved.  
 Filename: W:\9275\Electrical\Plans\9275-E13-011ContD11.dwg  
 Layout Name: Layout1  
 Plotted: Monday, August 01, 2016 - 10:43 am  
 By: B.S.

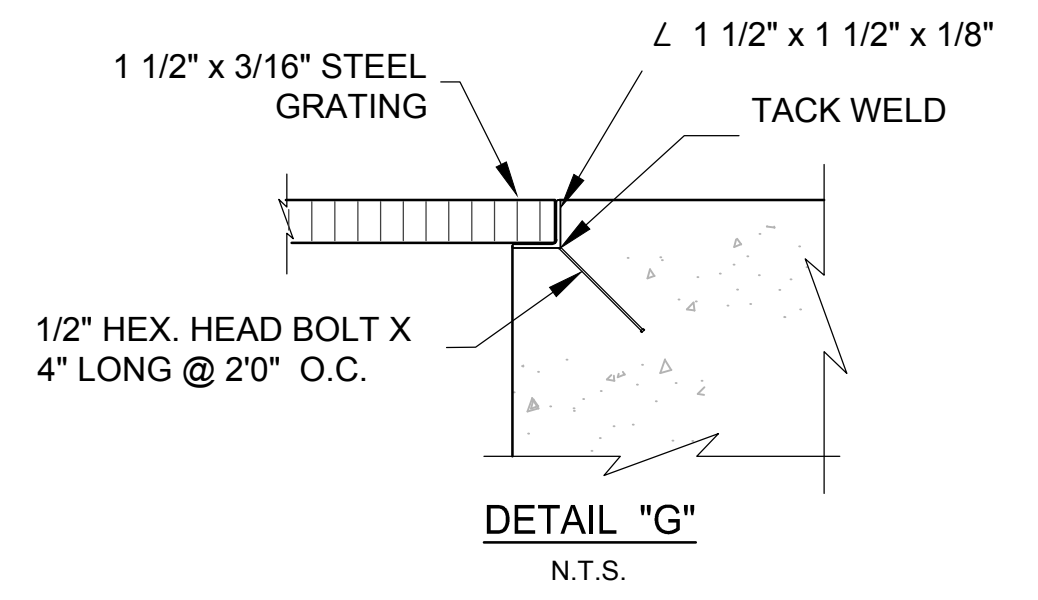
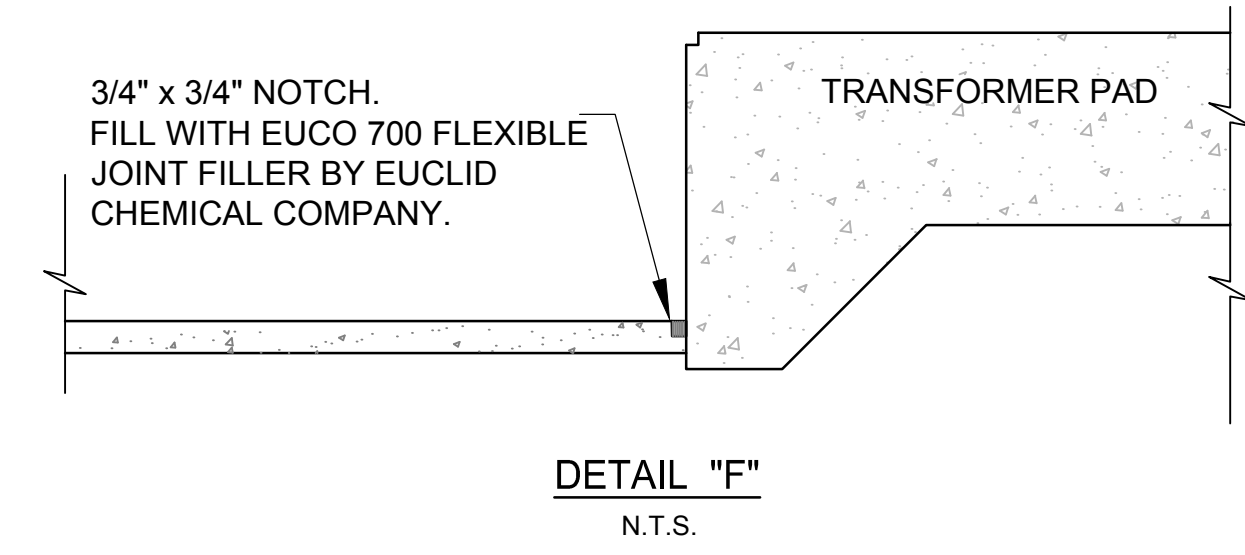
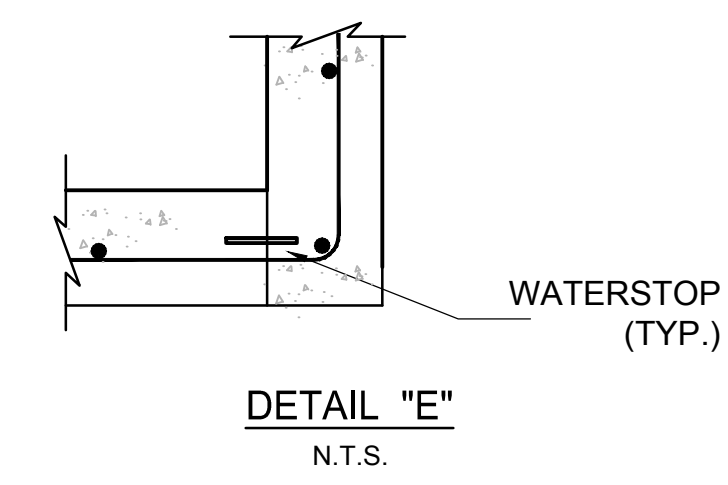
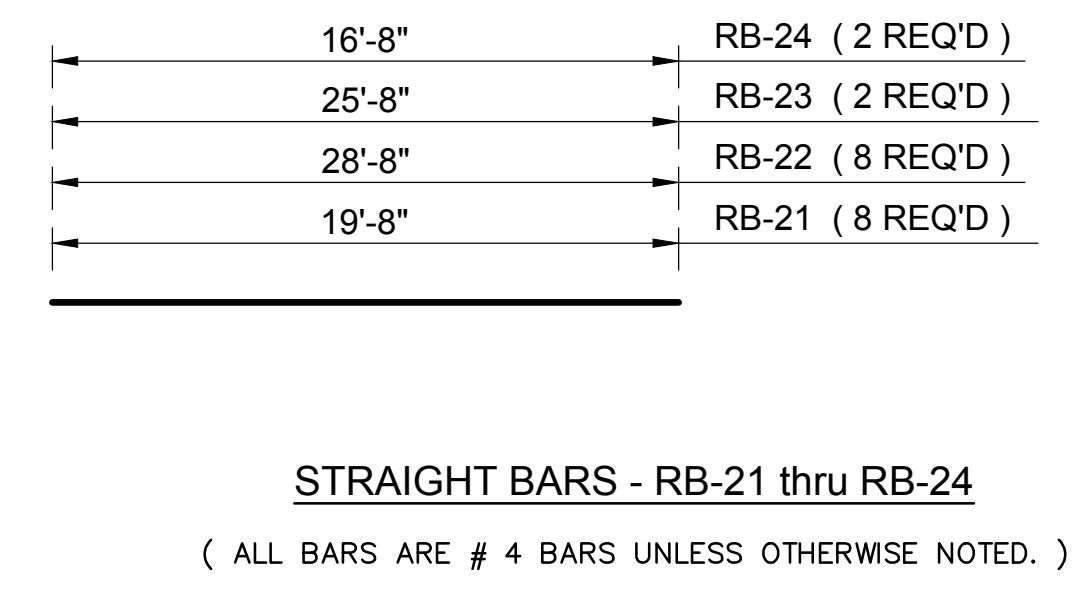
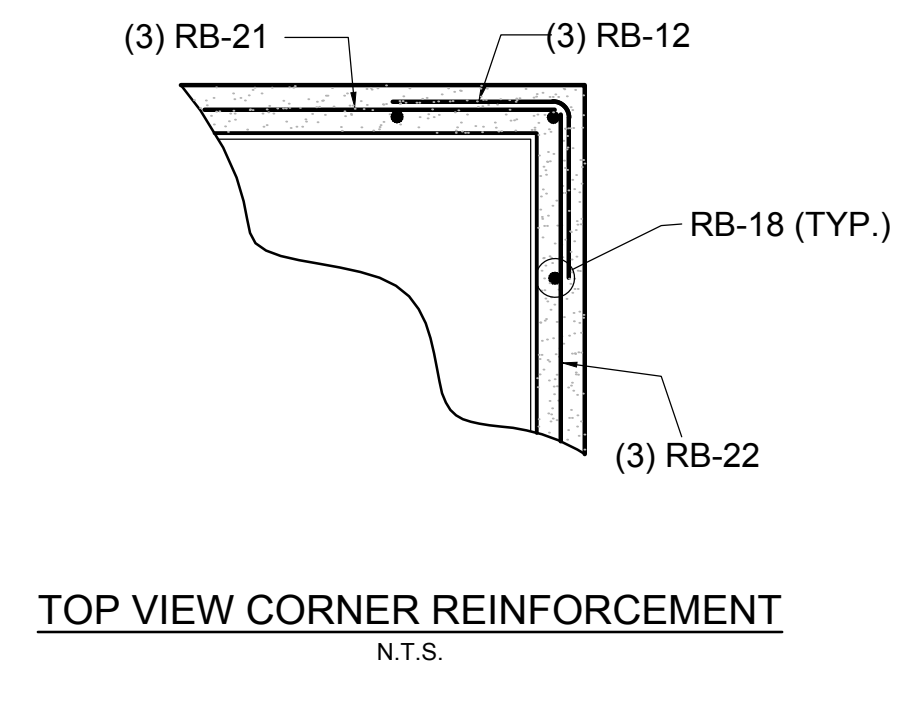
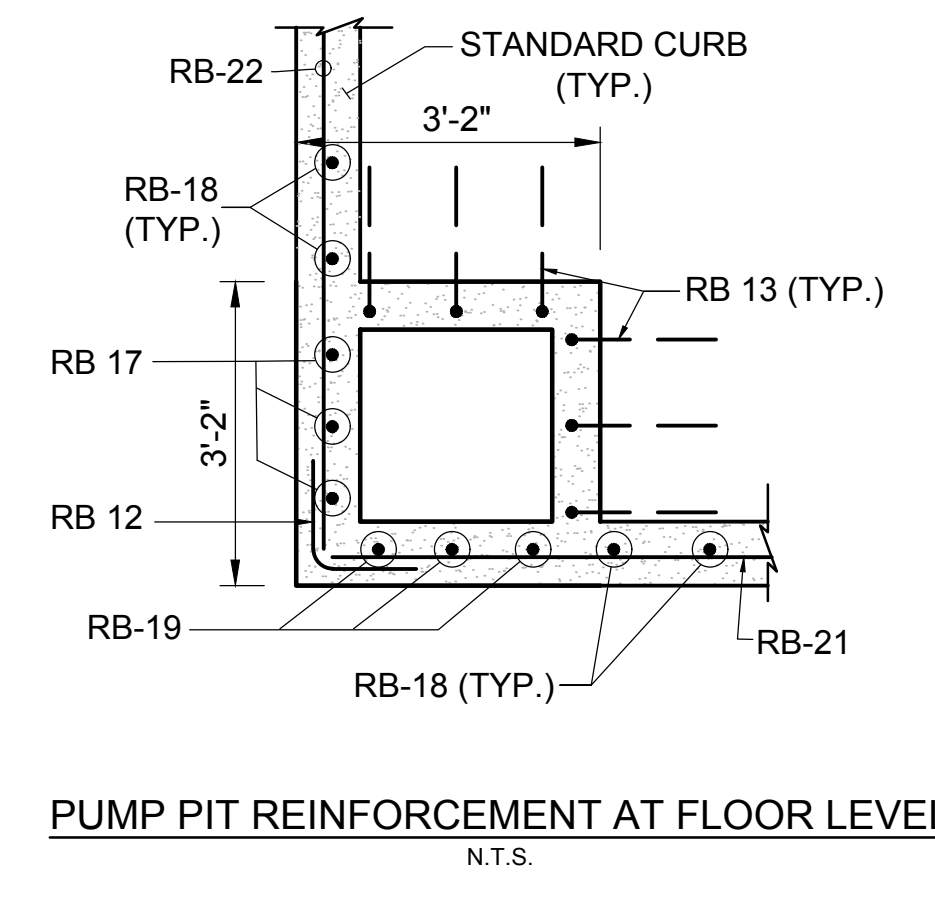
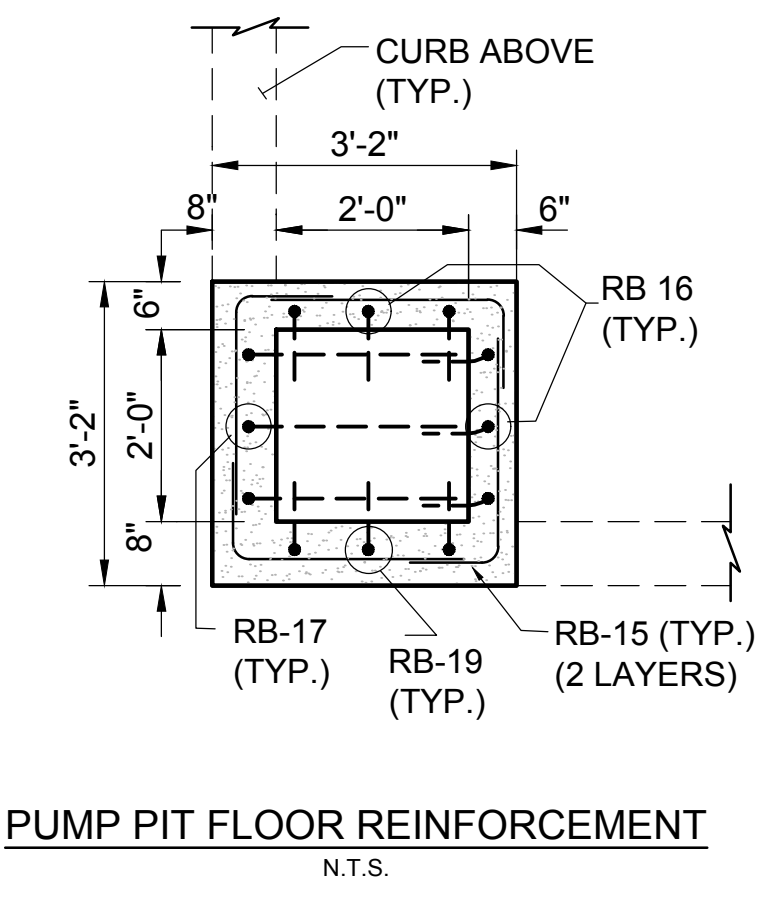
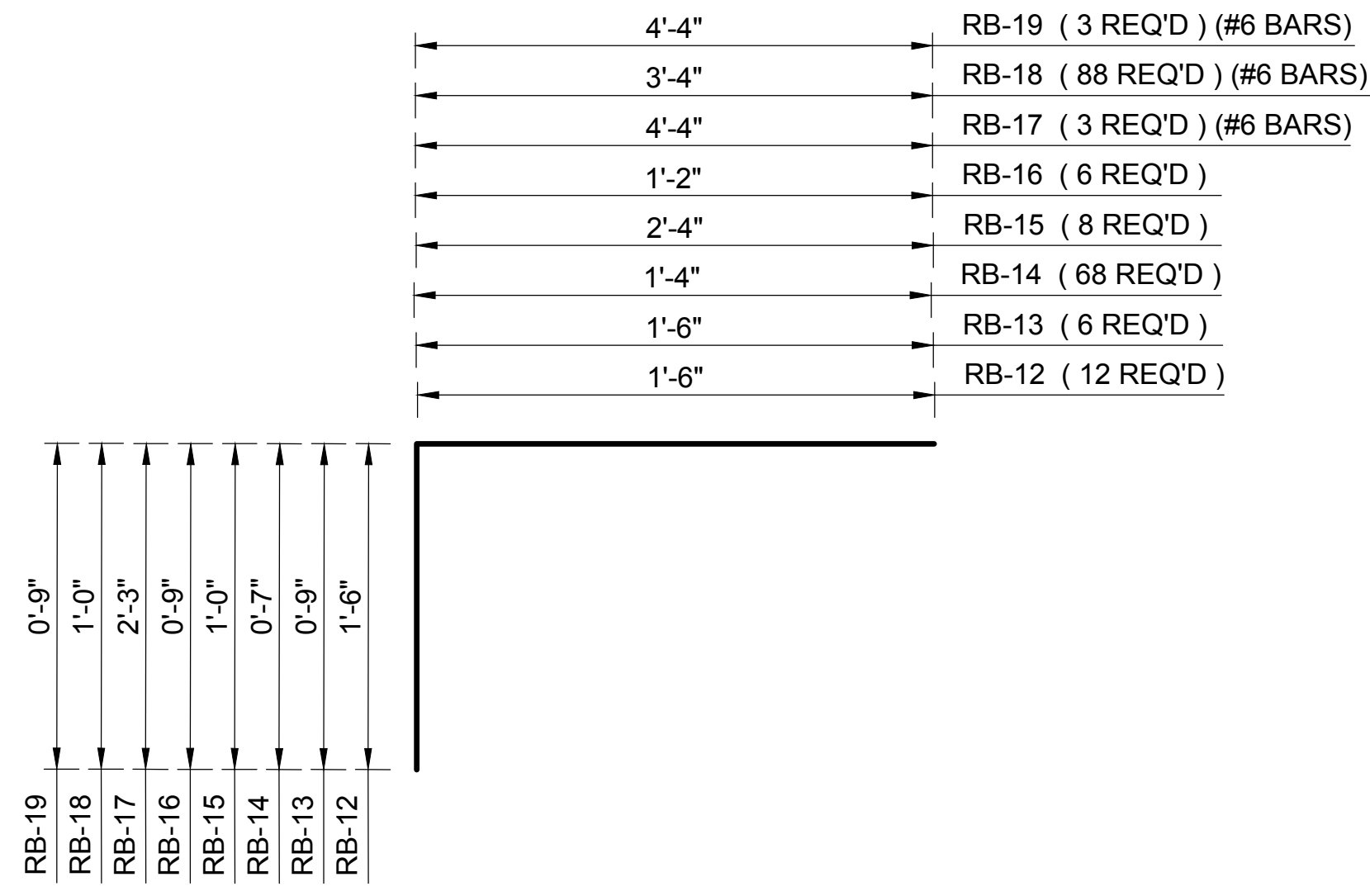
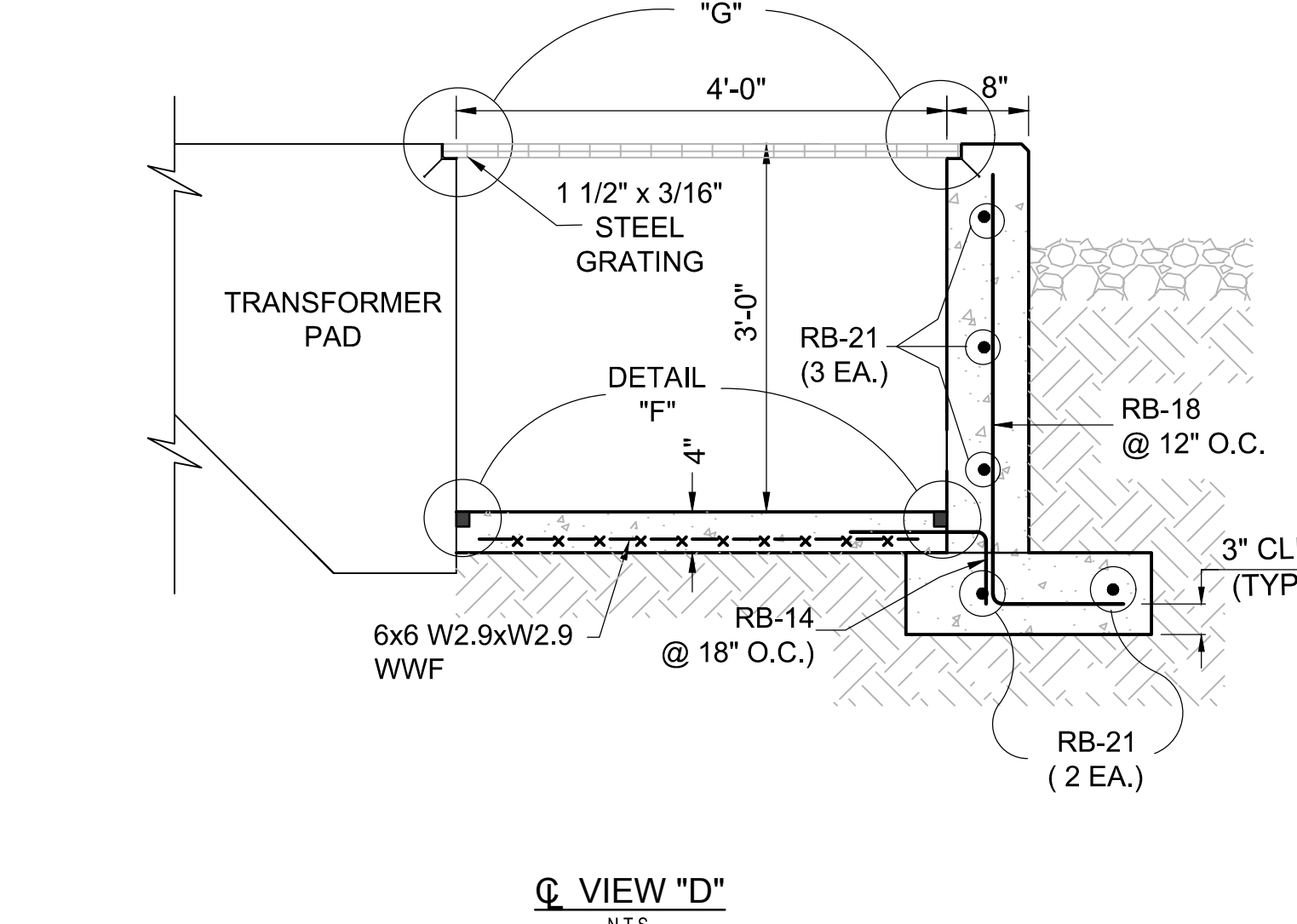
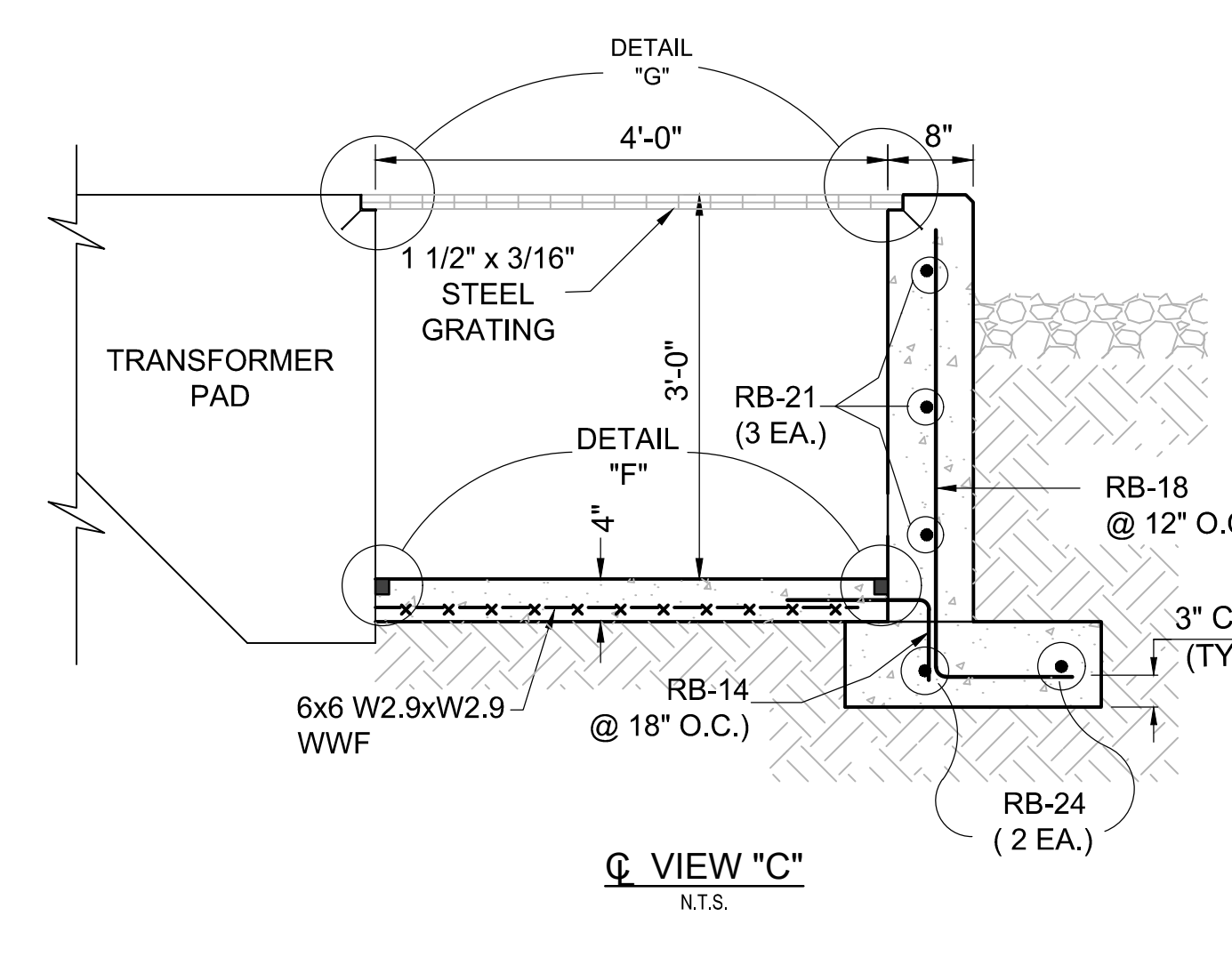
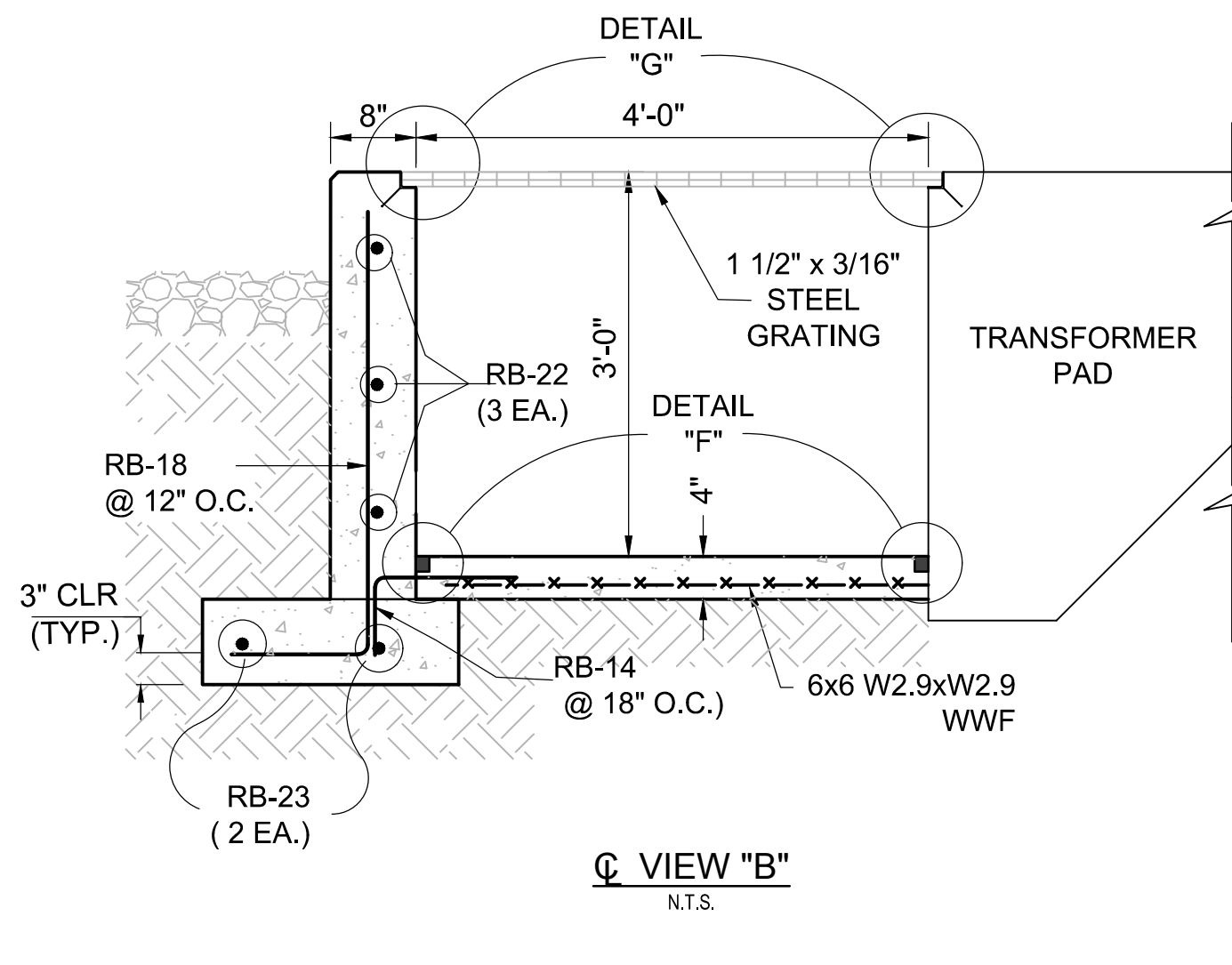
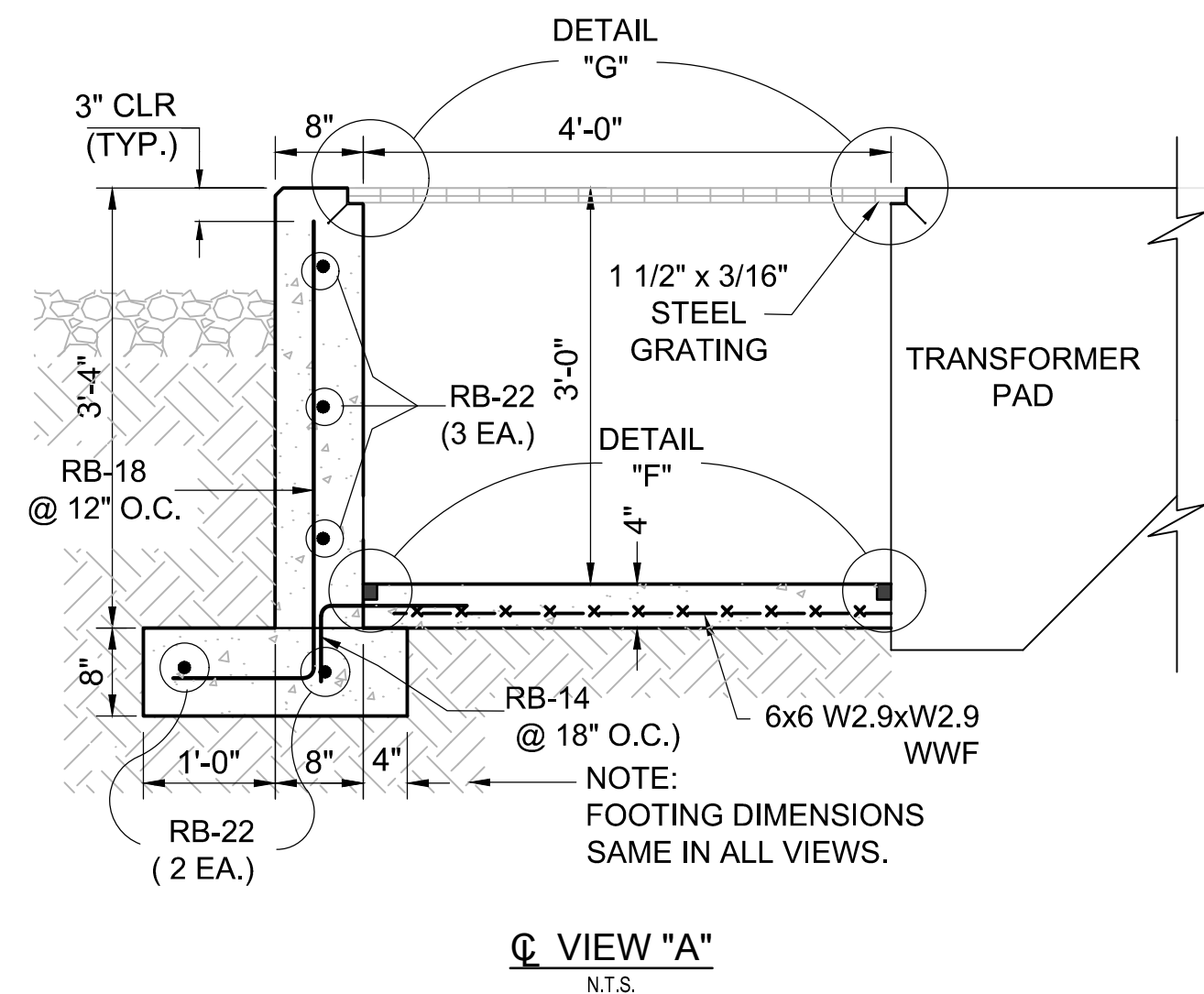

**BID DOCUMENT**  
**NOT FOR CONSTRUCTION**

Rev.	Date	Revision Description

Seal

Issue Date: JULY 2016  
 Project No: H9275  
 Dwg File: 9275-E13-011ContD11  
 Drawn By: B.S.  
 Checked By: G.H.M.

OIL CONTAINMENT DETAILS

Copyright 2016 Fisher & Arnold, Inc. All rights reserved.  
 Filename: W:\9275\Electrical\Plans\8275-E14-GratingPin.dwg  
 Layout Name: GRATING  
 Plotted: Thursday, July 28, 2016 - 4:29 pm  
 By: B.S.

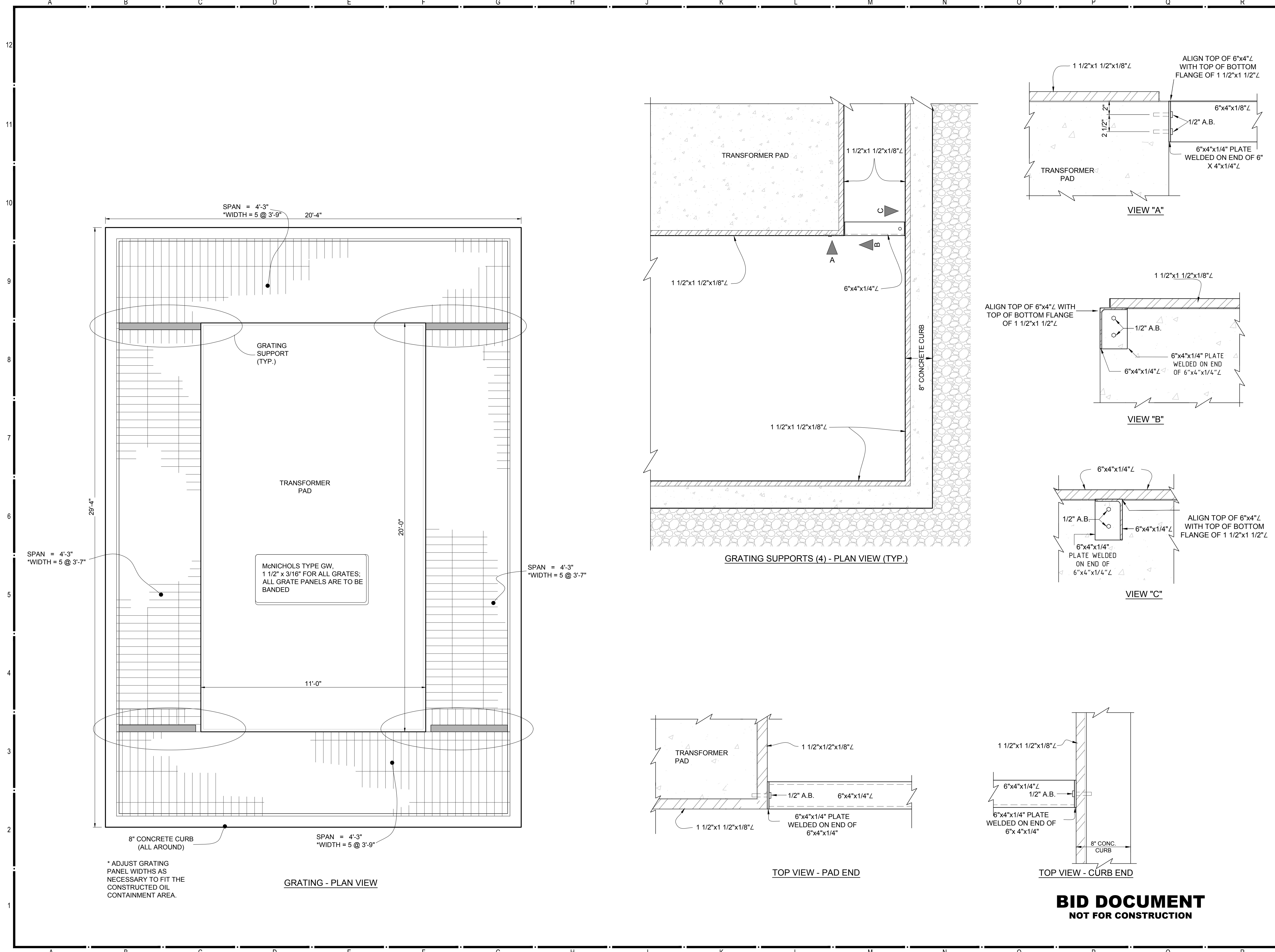

**FISHER ARNOLD**  
 ENGINEERING INTEGRATION

9180 Crestwyn Hills Drive | Memphis, Tennessee 38125-8538  
 901.748.1811 | Fax: 901.748.3115 | www.fisherarnold.com  
 © 2016 Fisher & Arnold, Inc., all rights reserved.

North Little Rock Electric Dept.  
 McCain Substation Improvements  
 North Little Rock, Arkansas

Rev.	Date	Revision Description

Seal

Issue Date: JULY 2016  
 Project No: H9275  
 Dwg File: 8275-E14-GratingPin  
 Drawn By: B.S.  
 Checked By: G.H.M.

GRATING LAYOUT PLAN