

CITY OF NORTH LITTLE ROCK, ARKANSAS  
COMMERCE DEPARTMENT  
Mary Beth Bowman, Director  
Amy Smith, Assistant Director for Procurement  
Crystal Willis, Assistant Purchasing Agent/Admin Sect.



120 Main Street, North Little Rock, AR 72114  
P.O. Box 5757 North Little Rock, AR 72119  
501-975-8881 Phone  
501-975-8885 Fax

### INVITATION TO BID

Bid Number: 19-3581 Date Issued: March 15, 2019

Date & Time Bid Opening: Monday, April 1, 2019 @ 10:15 am

## TRANSFORMERS FOR THE NORTH LITTLE ROCK ELECTRIC DEPARTMENT

Type	KVA	Voltage	Quantity	Price @ Each	ETA
Three Phase	500	277/480	4		

**Manufacturer:** \_\_\_\_\_

Specifications attached.

For technical questions and/or comments, contact Greg Woodward at 501-992-4073.

Questions regarding shipping and receiving should be directed to Karen Allen at 501-992-4058

General Bidding questions should be directed to the Commerce Department at 501-975-8881.

If you are obtaining this bid from our website, please be reminded that addendums may occur. It is therefore advisable that you review our listings for attachments including any changes to the bid.

The City of North Little Rock encourages participation of small, minority, and woman own business enterprises in the procurement of goods, services, professional services, and construction, either as a general contractor or sub-contractor. It is further requested that whenever possible, majority contractors who require sub-contractors, seek qualified small, minority, and woman businesses to partner with them.

### EXECUTION OF BID

Upon signing this page, the organization certifies that they have read and agree to the requirements set forth in this bid including conditions set forth and pertinent information requests.

Name of Firm: \_\_\_\_\_ Phone No.: \_\_\_\_\_

Tax Identification No.: \_\_\_\_\_

Business Address: \_\_\_\_\_

Signature of Authorized Person: \_\_\_\_\_

Title: \_\_\_\_\_ Date: \_\_\_\_\_

**UNSIGNED BID COVER SHEET WILL BE REJECTED.**

**GENERAL TERMS AND CONDITIONS FOR THE CITY OF NORTH LITTLE ROCK, AR**

1. When submitting an "Invitation to Bid," the bidder warrants that the commodities covered by the bid shall be free from defects in material and workmanship under normal use and service. In addition, bidder must deliver new commodities of the latest design and model, unless otherwise specified in the "Invitation to Bid."
2. Prices quoted are to be net process, and when an error is made in extending total prices, the City may accept the bid for the lesser amount whether reflected by extension or by the correct multiple of the unit price.
3. Discounts offered will be taken when the City qualifies for such. The beginning date for computing discounts will be the date of invoice or the date of delivery and acceptance, whichever is later.
4. When bidding other than the brand and/or model specified in the "Invitation to Bid," the brand and/or model number must be stated by that item in the "Invitation to Bid," and descriptive literature be submitted with the bid.
5. The City reserves the right to reject any and all bids.
6. The Purchasing office reserves the right to award items, all or none, or by line item(s).
7. Quality, time and probability of performance may be factors in making an award.
8. Bid quotes submitted will remain firm for 30 calendar days from bid opening date; however, the prices may remain firm for a longer period of time if mutually agreeable between bidder and the Department of Commerce.
9. Bidder must submit a completed signed copy of the front page of the "Invitation to Bid" and must submit any other information required in the "Invitation to Bid."
10. In the event a contract is entered into pursuant to the "Invitation to Bid," the bidder shall not discriminate against any qualified employee or qualified applicant for employment because of race, sex, color, creed, national origin or ancestry. The bidder must include in any and all subcontracts a provision similar to the above.
11. Sales or use tax is not to be included in the bid price, but is to be added by the vendor to the invoice billing to the City. Although use tax is not to be included in this bid, vendors are to register and pay tax direct to the Arkansas State Revenue Department.
12. Prices quoted shall be "Free on Board" (F.O.B.) to destination at designated facility in North Little Rock. Charges may not be added after the bid is opened.
13. In the event of two or more identical low bids, the contract may be awarded arbitrarily or for any reason to any of such bidders or split in any proportion between them at the discretion of the Department of Commerce..
14. Specifications furnished with this Invitation are intended to establish a desired quality or performance level, or other minimum dimensions and capacities, which will provide the best product available at the lowest possible price. Other than designated brands and/or models approved as equal to designated products shall receive an equal consideration.
15. Samples of items when required, must be furnished free, and, if not called for within 30 days from date of bid opening, will become property of the City.
16. Bids will not be considered if they are:
  1. Submitted after the bid's opening time.
  2. Submitted electronically or faxed (unless authorized by Purchasing Agent).
17. Guarantees and warranties should be submitted with the bid, as they may be a consideration in making an award.

18. **CONSTRUCTION**

- A. Contractor is to supply the City with evidence of having and maintaining proper and complete insurance, specifically Workman's Compensation Insurance in accordance with the laws of the State of Arkansas, Public Liability and Property Damage. All premiums and cost shall be paid by the Contractor. In no way will the City be responsible in case of accident.
- B. When noted, a Certified check or bid bond in the amount of 5% of total bid shall accompany bid.
- C. A Performance Bond equaling the total amount of any bid exceeding \$35,000.00 must be provided for any contract for the repair, alteration or erection of any public building, public structure or public improvement (pursuant to Arkansas Code Annotated Section 22-9-203).

19. **LIQUIDATED DAMAGES** - Liquidated damages shall be assessed beginning on the first day following the maximum delivery or completion time entered on this bid form and/or provided for by the plans and specifications.

20. **AMBIGUITY IN BID** - Any ambiguity in any bid as the result of omission, error, lack of clarity or non-compliance by the bidder with specifications, instructions, and all conditions of bidding shall be construed in the light most favorable to the City.

21. The bid number should be stated on the face of the sealed bid envelope. If it is not, the envelope will have to be opened to identify.

22. Whenever a bid is sought seeking a source of supply for a specified period of time for materials and services, the quantities of usage shown are estimated ONLY. No guarantee or warranty is given or implied by the participants as to the total amount that may or may not be purchased from any resulting contracts. These quantities are for the bidders information ONLY and will be used for tabulation and presentation of bid and the participant reserves the right to increase or decrease quantities as required.

23. The City of North Little Rock reserves the right to reject any and all bids, to accept in whole or in part, to waive any informalities in bids received, to accept bids on materials or equipment with variations from specifications in those cases where efficiency of operation will not be impaired, and unless otherwise specified by the bidder, to accept any item in the bid. If unit prices and extensions thereof do not coincide, the City of North Little Rock may accept the bid for the lesser amount whether reflected by the extension or by the correct multiple of the unit price.

24. Additional information or bid forms may be obtained from:  
COMMERCE DEPARTMENT, 120 Main Street, P.O. Box 5757, North Little Rock, Arkansas 72119 (501)975-8881  
[www.nlr.ar.gov](http://www.nlr.ar.gov)

**Bidding documents must be submitted on or before the bid's opening date and time. Unless noted, bids must be sealed and mailed or delivered to:**

**Commerce Department  
120 Main Street (P.O. Box 5757)  
North Little Rock, AR 72119**

ELECTRIC DEPARTMENT



1400 West Maryland Ave., North Little Rock, AR 72120  
P.O. Box 159, No Little Rock, AR 72115-0159  
501-372-0100

## NORTH LITTLE ROCK ELECTRIC DEPARTMENT

### PAD MOUNT TRANSFORMERS

### BID NOTATIONS

North Little Rock Electric Department Specifications are attached.

Questions regarding the specifications and/or requirements should be directed to Greg Woodard at 501-992-4073.

Questions regarding shipping and receiving should be directed to Karen Allen at 501-992-4058.

- Vendors are to reference the NLRED specification handbook on three phase pad mount transformers.
- **Must notify NLRED a minimum of 48 hours prior to delivery of material.**
- Delivery requirements are as follows:  
Transformers are to be delivered to NLRED Palm Street Location  
830 N Palm Street  
N Little Rock, AR 72114  
(Google Map Location is shown as 959 N Palm St, N. Little Rock, AR)
- Delivery contacts: Karen Allen/Warehouse at 501-992-4058  
Brenda Davidson/Purchasing at 501-992-4026  
Greg Woodward/Engineering at 501-992-4073
- Receiving Hours: Regular receiving hours are 8:00am – 3:00pm, Monday – Friday.



**THREE-PHASE DEAD FRONT PADMOUNTED TRANSFORMER WITH  
ALTERNATE/LOOP FEEDING SWITCH**

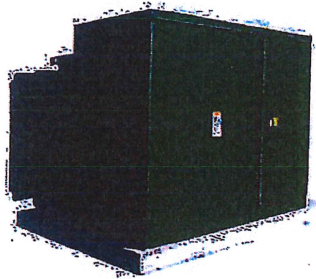

**NORTH LITTLE ROCK ELECTRIC DEPARTMENT**

**1400 W. MARYLAND AVE**

**P.O. BOX 159**

**NORTH LITTLE ROCK, AR 72115**

**501-372-0100**

NORTH LITTLE ROCK ELECTRIC DEPARTMENT  
THREE-PHASE DEAD FRONT PADMOUNTED TRANSFORMER  
WITH ALTERNATE/LOOP FEEDING SWITCH

1.0 SCOPE

1.1 THIS SPECIFICATION SHALL BE IN ACCORDANCE WITH THE AMERICAN NATIONAL STANDARD INSTITUTE C57.12.22, LATEST REVISION THEREOF, WITH STIPULATIONS AS REQUIRED IN THE FOLLOWING PARAGRAPHS:

2.0 RATING

2.1 KILOVOLT-AMPERE RATING

KILOVOLT-AMPERE RATING SHALL BE:

150  
300  
500  
750  
1000  
1500

AS SPECIFIED.

2.2 VOLTAGE RATING AND TAP RATINGS

2.2.1 VOLTAGE RATING SHALL BE:

13200 GRDY - 208Y/120  
13200 GRDY - 480Y/277 OR

AS SPECIFIED, WITH 5 LEGGED CORE.

2.2.2 VOLTAGE TAPS SHALL BE AS FOLLOWS:

13860/13530/13200/12870/12540/FULL CAPACITY

3.0 BASIC IMPULSE INSULATION LEVELS

3.1 BASIC IMPULSE INSULATION LEVELS (BIL) SHALL BE:

<u>RATED HIGH VOLTAGE</u>	<u>BIL-KV</u>	<u>INSULATION CLASS KV</u>
13200	95	15
<u>RATED LOW VOLTAGE</u>	<u>BIL-KV</u>	<u>INSULATION CLASS KV</u>
208 Y/120	30	1,2
480 Y/277	30	1,2

4.0 CONSTRUCTION

4.1 HIGH VOLTAGE BUSHINGS

4.1.1 SIX HIGH VOLTAGE BUSHING WELLS SHALL BE EXTERNALLY CLAMPED TO THE TANK WALL. THE ARRANGEMENT AND LOCATION OF THE HIGH VOLTAGE BUSHING WELLS SHALL BE AS SHOWN IN FIGURE 1. THE BUSHING WELLS SHALL BE:

ELASTIMOLD NO. K1601-PC-S2  
CENTRAL MOLONEY COMPONENT NO. 3-701981-50  
CENTRAL MOLONEY COMPONENT NO. 3-7022-1165  
OR APPROVED EQUIVALENT.

4.1.2 THE HIGH VOLTAGE BUSHING WELLS SHALL BE EQUIPPED WITH THE FOLLOWING LOAD BREAK INSERTS:

ELASTIMOLD NO. 1601-A3R  
GENERAL ELECTRIC NO. 9U02AAB001  
RTE. NO. 2604797B01M  
BLACKBURN NO. JLB28B10C

4.2 LOW VOLTAGE BUSHINGS

4.2.1 THE LOW VOLTAGE LINE AND NEUTRAL TERMINALS SHALL BE TINPLATED COPPER IN ACCORDANCE WITH FIGURE 2 AND ARRANGED FOR VERTICAL TAKE-OFF.

4.2.2 THE LOW-VOLTAGE NEUTRAL SHALL BE A FULLY INSULATED BUSHING GROUNDED TO THE GROUND PAD PROVIDED ON THE OUTER SURFACE OF THE TANK WITH A REMOVABLE GROUND STRAP AND SHALL BE INDEPENDENT OF ALL OTHER CONNECTIONS, THE GROUND STRAP SHALL BE ADEQUATE TO CARRY THE MAXIMUM AVAILABLE FAULT CURRENT.

4.3 FUSING

THE TRANSFORMER SHALL BE EQUIPPED WITH A RTE, OR EQUAL, DUAL PURPOSE BAYONET TYPE, OIL IMMERSSED FUSES WITH SERIES CONNECTED, OVERLOAD SENSING AND ISOLATION LINK FUSING. THE FUSING SHALL BE MOUNTED ON THE HIGH VOLTAGE SIDE OF TRANSFORMER.

4.4 ALTERNATE-FEED/LOOP FEED LOAD-BREAK SWITCHES

TRANSFORMER IS TO COME EQUIPPED WITH EXTERNALLY OPERATED, 3 PHASE, 4 POSITION, 300 AMPERE INTERNAL OIL IMMERSSED DUAL SUPPLY "LOOP FEED" LOAD BREAK SECTIONALIZING SWITCH. (V-BLADE TYPE SWITCH)

4.5 ACCESSORY EQUIPMENT

ACCESSORY EQUIPMENT IS THAT EQUIPMENT PROVIDED AS PART OF THE STANDARD TRANSFORMER.  
ACCESSORY EQUIPMENT SHALL BE AS FOLLOWS:

PRESSURE VACUUM GAUGE, PSI, 1/4" N.P.T. AND EQUIPPED WITH PURGE VALVE WITH SPIGOT FOR 1/4 I.D. HOSE.

DIAL-TYPE THERMOMETER WITH SEALED WELL, NEMA STANDARED 7.612, LATEST REVISION.

TAP CHANGER HANDLE IN COMPARTMENT.

INSTRUCTION NAMEPLATE INSIDE LOW-VOLTAGE COMPARTMENT.

1" DRAIN VALVE WITH BUILT-IN SAMPLING DEVICE.

1" UPPER FILTER PRESS AND FILLING PLUG (OR CAP).



ALTERNATE/LOOP FEED NAMEPLATE.

PARKING STANDS MOUNTED ON THE TANK AS SHOWN IN FIGURE 1 AND IN FIGURE 3.

4.6 CABINET SECURITY

PRIMARY AND SECONDARY COMPARTMENT SHALL INTERLOCK AND BE EQUIPPED FOR PAD LOCKING AND PROVISION SHALL BE MADE FOR SECURING TRANSFORMER TO A CONCRETE PAD.

5.0 FINISH

INTRODUCTION

THE OBJECTIVE OF THIS SPECIFICATION IS TO DESCRIBE A HIGH QUALITY COATING SYSTEM FOR CARBON STEEL PADMOUNTED EQUIPMENT, PROVIDE LONG FIELD LIFE WITH A MINIMUM OF MAINTENANCE. THE COATING SHALL HAVE EXCELLENT WEATHERING CHARACTERISTICS WITH A MINIMUM OF CHALKING, HIGH RESISTANCE TO CORROSIVE ENVIROMENTS SUCH AS SALT SPRAY AND HIGH RESISTANCE TO ABRASION, SCRATCHING AND CHIPPING. MORE STRINGENT PERFORMANCE REQUIREMENTS MAY BE NEEDED TO PROVIDE LONG FIELD LIFE IN SEVERE ENVIRONMENTS.

6.0 EQUIPMENT DESIGN OBJECTIVES

- 6.1 THE EQUIPMENT SHALL BE DESIGNED TO MINIMIZE AREAS WHERE WATER AND CORROSIVE ELEMENTS CAN ACCUMULATE.
- 6.2 ALL WELDS SHALL BE TREATED TO PREPARE THE WELD SURFACES FOR COATING. WELD SPATTER SHALL BE REMOVED.
- 6.3 THE MANUFACTURER SHALL PROVIDE A METHOD OF SHIPMENT THAT WILL ALLOW THE EQUIPMENT TO BE RECEIVED BY THE PURCHASER SUCH THAT IT STILL MEETS THE PERFORMANCE TESTS REQUIRED, BY THIS SPECIFICATION.

- 6.4 THE MANUFACTURER SHALL PROVIDE A MEANS, PREFERABLY AS AN INHERENT PART OF THE EQUIPMENT, TO MINIMIZE SCRATCHING OF THE COATING ON THE BASE OF THE EQUIPMENT DURING HANDLING AND INSTALLATION.

7.0 FINISH REQUIREMENTS

- 7.1 ALL COATED SURFACES ON THE EXTERIOR OF THE EQUIPMENT AND ON THE INTERIOR OF THE CABINET SHALL BE CAPABLE OF MEETING THE PERFORMANCE TESTS REQUIRED BY THE SPECIFICATION.
- 7.2 IF MORE THAN ONE COATING SYSTEM IS USED FOR DIFFERENT AREAS OF THE EQUIPMENT, THE AREA WHERE EACH IS USED SHALL BE IDENTIFIED. FOR EACH COATING SYSTEM, THE METHOD OF SURFACE PREPARATION, METHOD OF COATING, MINIMUM DRY BUILD THICKNESS AND CURING CYCLE OF EACH COATING, THE MINIMUM DRY BUILD THICKNESS OF THE TOTAL COATING SYSTEM AND THE LABORATORY TEST PERFORMANCE DATA OF THE TOTAL COATING SYSTEM PER THIS SPECIFICATION SHALL BE SUBMITTED TO THE USER FOR APPROVAL UPON REQUEST. THIS DATA SHALL BE RESUBMITTED TO THE USER WHENEVER THERE ARE SIGNIFICANT DEPARTURES FROM THESE METHODS AND/OR MATERIALS. IT SHALL BE THE RESPONSIBILITY OF THE USER TO PERFORM ANY ADDITIONAL TESTING NOT REQUIRED BY THIS SPECIFICATION.
- 7.3 THE TOPCOAT COLOR SHALL BE MUNSELL 7GY 3.29/1.5 GREEN.
- 7.4 TOUCH-UP SHALL BE DONE ON FINAL INSPECTION BEFORE ANY EQUIPMENT IS SHIPPED. IN AREAS WHERE THE INTEGRITY OF BOTH THE PRIMER AND THE FINISH COAT IS VIOLATED, TOUCH-UP SHALL BE WITH BOTH PRIMER AND FINISH COAT. IN ALL CASES, THE FINAL COAT TOUCH-UP SHALL BLEND SMOOTHLY WITH THE ORIGINAL FINISH.
- 7.5 A COATING SYSTEM MAINTENANCE PROCEDURE SHALL BE RECOMMENDED BY THE MANUFACTURER.

8.0 TEST SPECIMENS

- 8.1 SUBSTRATES SHALL CONSIST OF PANELS OF THE SAME

MATERIAL, LIGHTEST GAUGE, AND PROCESSING AS USED IN PRODUCTION. ALL PANELS SHALL BE CLEANED, COATED AND CURED USING THE PRODUCTION COATING SYSTEM.

9.0 INFORMATION REQUIRED WITH PROPOSAL

- 9.1 CERTIFIED DATA SHOWING CONFORMANCE TO THE PERFORMANCE REQUIREMENTS, PARAGRAPH 5.1.
- 9.2 GUARANTEED MAXIMUM NO LOAD LOSSES, WINDING LOSSES AND IMPEDANCE BASED ON 85 DEGREES CELSIUS.
- 9.3 FURNISH ONE COPY OF OUTLINE DRAWING, OF COMPLETE PADMOUNTED ASSEMBLY, NAMEPLATE DRAWING, DETAIL DRAWING OF TERMINAL ENCLOSURE AND EQUIPMENT ELEVATION CUT AWAY.
- 9.4 A STATEMENT THAT ALL THE REQUIREMENTS OF THIS SPECIFICATION WILL BE MET OR A STATEMENT WHICH COMPLETELY DESCRIBES THE EXCEPTIONS IN THE VENDOR'S PRODUCT.
- 9.5 ALTERNATE PROPOSALS WILL BE GIVEN CONSIDERATION.
- 9.6 UPON RECEIPT OF ORDER, FURNISH THREE COPIES OF OUTLINE AND NAMEPLATE DRAWING FOR APPROVAL.
- 9.7 THREE COPIES OF APPROVED FINAL OUTLINE AND NAMEPLATE DRAWINGS AND INSTALLATION AND MAINTENANCE DRAWINGS SHALL BE FURNISHED BEFORE FABRICATION OF TRANSFORMERS.

FIGURE 1

1. FUSES

2. ALTERNATE/LOOP FEED SWITCH

3. ALTERNATE/LOOP FEED NAMEPLATE

3/4" MIN.  
1 1/2" MAX.  
FLANGE

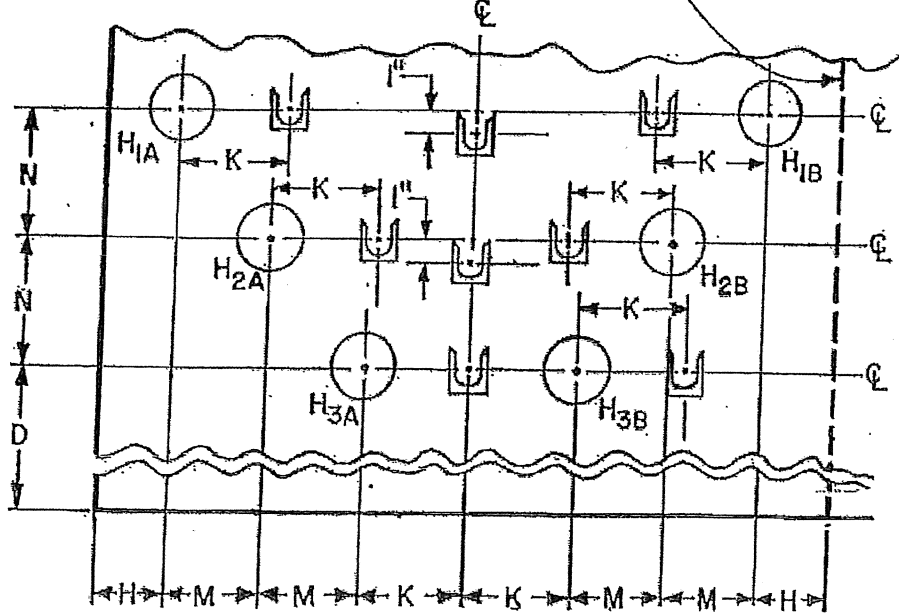
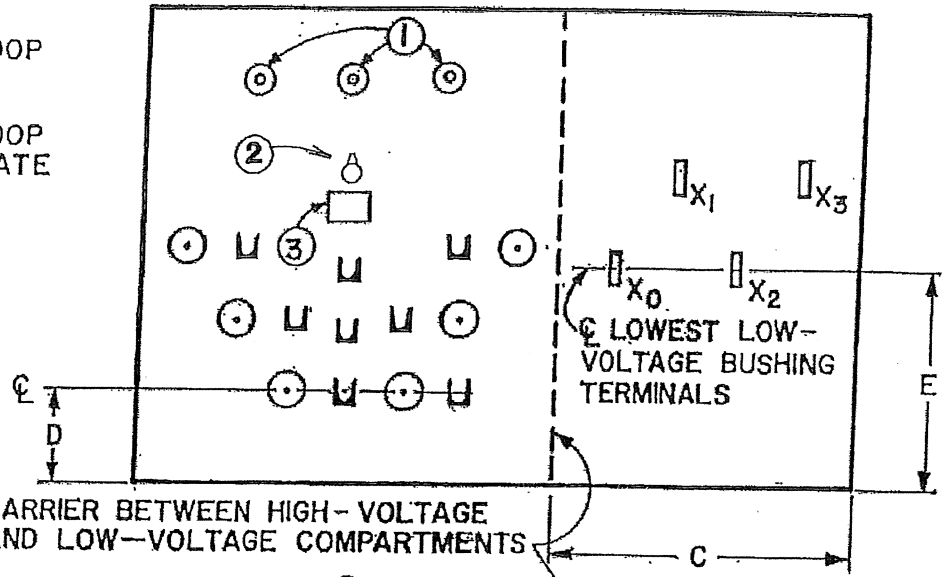
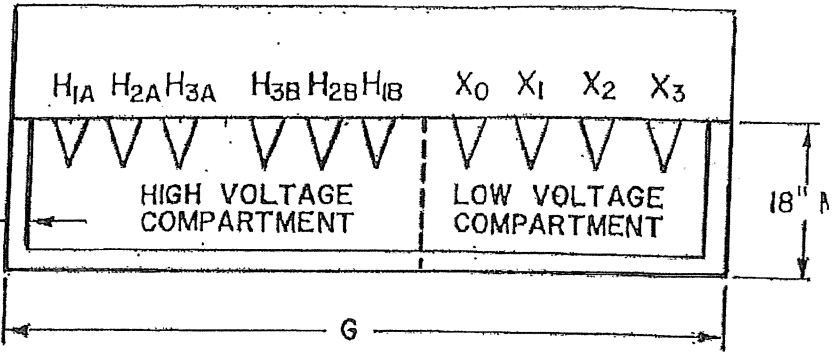

KVA	C	D	E	G	H	K	M	N
150	24" MIN.	27 ± 1/2"	27 ± 1/2"	59" MIN.	3 1/2" MIN.	5"	4 1/2"	6"
300-500	27" MIN.	27 ± 1/2"	31 ± 1/2"	62" MIN.	3 1/2" MIN.	5"	4 1/2"	6"
750-1500	27" MIN.	27 ± 1/2"	46 ± 1/2"	62" MIN.	3 1/2" MIN.	5"	4 1/2"	6"

FIGURE 2

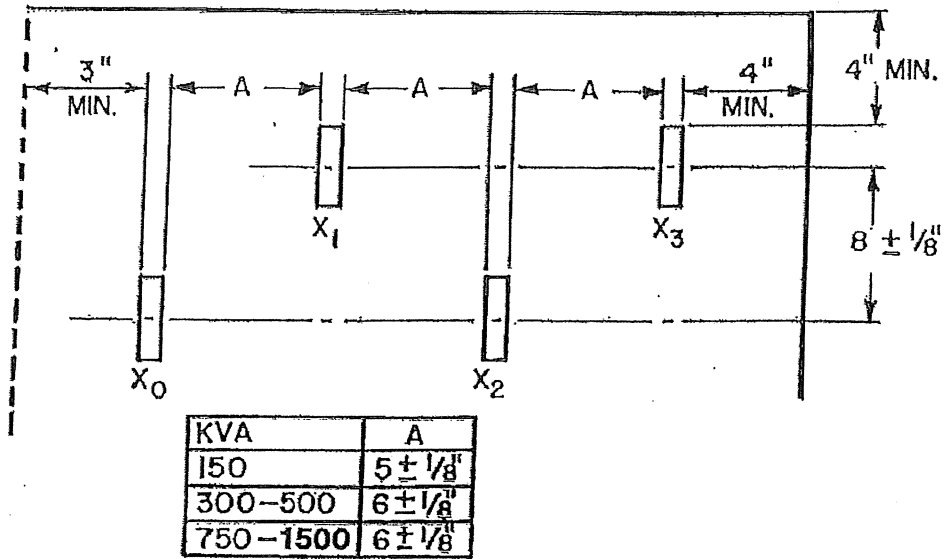

LOW VOLTAGE BUSHING TERMINALS AND ARRANGEMENTS

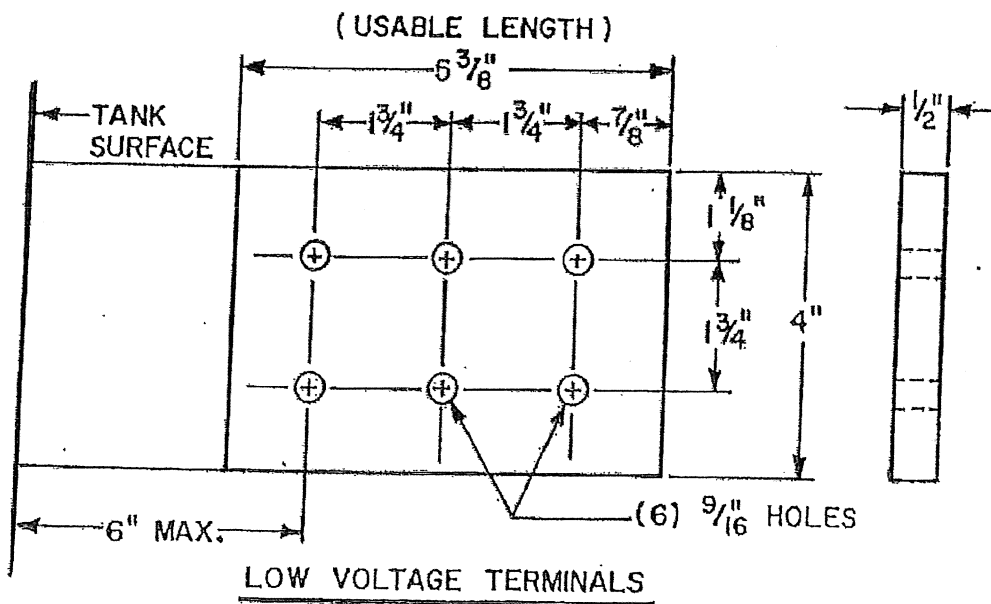
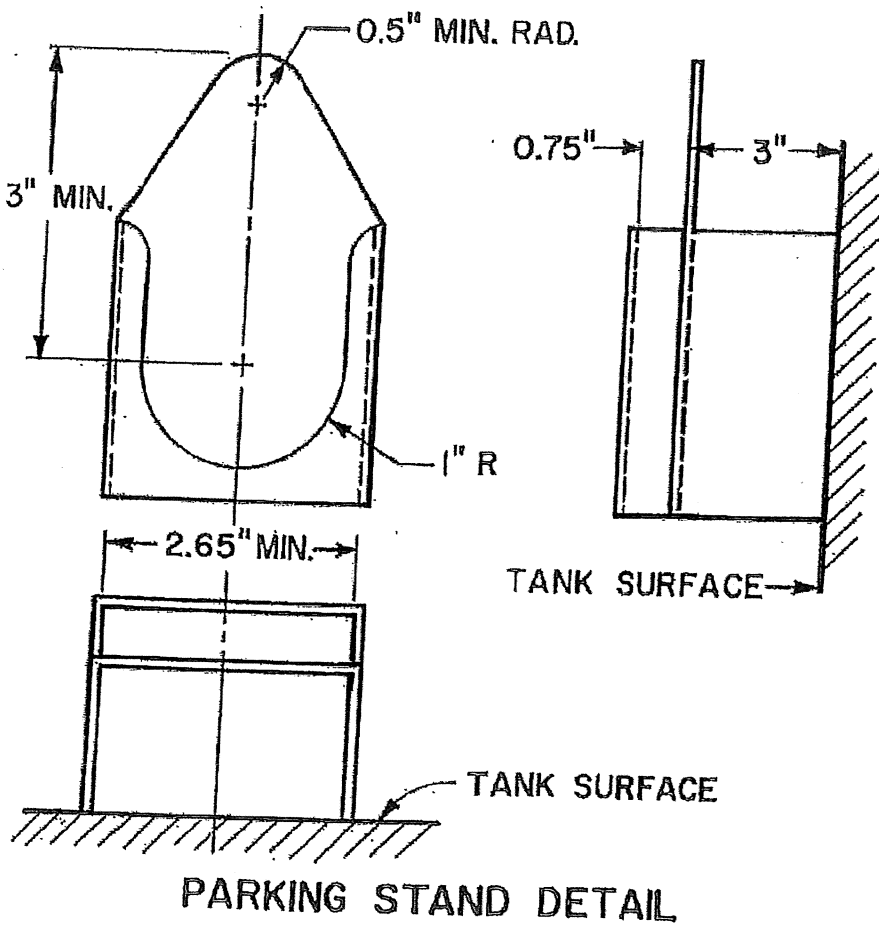

FIGURE 3



## **Term of Contract**

It is the intent of the City to enter into a one (1) year contract with the option to extend the contract for three (3) additional one (1) year periods upon mutual agreement of both parties. Contractor may increase their bid the additional years by no more than 5% by providing documentation for the increase.

## **Submission of Bids**

Sealed bid must be submitted to:

City of North Little Rock  
Commerce Department  
120 Main Street  
North Little Rock, AR 72114

## **Firm Pricing for City Acceptance**

Bid price must be firm for City acceptance for a minimum of ninety (90) days from bid opening date.

## **No Contact Policy**

Any contact with any City representatives, related officials, or representatives other than those outlined in the Bid is prohibited. Such unauthorized contact may disqualify the Contractor from this procurement.

## **W-9 Form Required**

Each bidder shall submit a completed W-9 form with their bid.

## **Acknowledgement of Contract**

By submitting a bid, the bidder acknowledges that it understands and agrees to the terms and conditions contained herein.

## **Bid Questions and Clarification**

All questions must be submitted in writing via email. Response to relevant questions will be posted on the Commerce web page at [nlr.ar.gov](http://nlr.ar.gov), click on the "Business" tab, then click on the "Bids and Vendors" tab, then click on "Current Bids".

Questions related to the Bid Specifications should be directed to:  
Greg Woodward at [gwoodward@nlr.ar.gov](mailto:gwoodward@nlr.ar.gov) or 501-992-4073.

## **Proposer's Certification**

By signature on the bid, the respondent certifies that it complies with:

- The laws of the state of Arkansas.
- All applicable local, state, and federal laws, codes, and regulations.
- All terms, conditions, and requirements set forth in this Bid.
- A condition that the Bid submitted was independently arrived at without collusion.

If any Respondent fails to comply with the provisions stated in this paragraph, the City reserve the right to reject the bid, terminate the contract, or consider the company/contractor in default.

### **Conflict of Interest**

Respondent, by responding to this Bid, certifies that to the best of his/her knowledge or belief, no elected/appointed official or employee of the City is financially interested, directly or indirectly, in the services specified in this Bid.

The City reserves the right to cancel the award if any interest disclosed from any source could either give the appearance of a conflict or cause speculation as to the objectivity of the respondent's proposal. The City's determination regarding any questions of conflict of interest is final.

### **Public Records**

Respondent understands that the bid is a "public record", and the public shall have access to all documents and information pertaining the Response and the Bid, subject to the provisions of Arkansas' FOIA. The Respondent, by submitting a bid, acknowledges that the City may provide public access to and/or copies of all documents subject to disclosure under applicable law.

### **Cost of Preparing Bid**

Any costs incurred in the preparation of the bids are solely the responsibility of the respondents. The City of North Little Rock will provide no reimbursements for such costs. Any cost associated with any oral representations to the City will be the responsibility of the respondent and may not be billed to the City.

### **Authority to Bind Firm in Contract**

Bids MUST give full firm name and address of bidder. Failure to manually sign bid may disqualify it. Person signing bid should show TITLE or AUTHORITY TO BIND THE CPMPANY/CONTRCTOR IN AN AGREEMENT. Firm name and authorized signature must appear on cover page of bid. See Exhibit "A" for draft Contract.

### **Late Bids**

LATE bids will be UNOPENED and disposed of in a proper manner.

### **Rights of City**

The City reserves the right to accept or reject all or any part of any bid, waive informalities and award the Contract to the lowest responsive and responsible bidder to best serve the interest of the City.

### **Basis for Award**

Contract award will be made to the lowest responsive and responsible bidder based upon the lump sum and meeting the specifications. (For clarification purposes, included in the lump sum is the unit item pricing and extended unit price items if applicable.)



## **Negotiation with the Lowest Responsible Bidder**

Unless all bids are cancelled or rejected, the City reserves the right to negotiate with the lowest responsive, responsible bidder to obtain a Contract price within the funds available whenever such low bid exceeds the available funds. Negotiations with the low bidder may include both modifications of the low price and the specifications/scope of work to be performed.