

# **PROJECT MANUAL**

## **REMOUNT & BATESVILLE PIKE GUARD RAIL**

**AUGUST 2021**

**NLR CITY ENGINEERING  
PROJECT NO. 21-24**

**Prepared By:**  
NLR City Engineering  
500 W. 13th Street  
North Little Rock, Arkansas 72114

**REMOUNT & BATESVILLE PIKE  
GUARD RAIL**

**City Engineering Project No. 21-24**

**PROJECT MANUAL**

**TABLE OF CONTENTS**

**NUMBER OF PAGES**

**BIDDING REQUIREMENTS**

Invitation to Bid/Proposal Cover Sheet .....	1
Advertisement to Bidders .....	2
General Terms and Conditions for the CNLR to Bidders.....	2
Bid Form .....	6
Bid Bond .....	2
Notice of Award.....	1
EJCDC C-610 Performance Bond .....	3
EJCDC C-615 Payment Bond.....	3

**CONTRACT FORMS**

Contract.....	29
Notice to Proceed.....	1

**CNLR STANDARD REQUIREMENTS**

EJCDC C-620 Application for Payment.....	4
EJCDC 1910-8-B Change Order .....	2
Contractor's Lien Release.....	1
EJCDC C-625 Certificate of Substantial Completion .....	2
Overhead High Voltage Reporting Form.....	1

CITY OF NORTH LITTLE ROCK, ARKANSAS  
COMMERCE DEPARTMENT  
Mary Beth Bowman, Director  
Amy Smith, Assistant Director for Procurement  
Crystal Willis, Admin. Sect./Assistant Purchasing Agent



120 MAIN STREET, North Little Rock, AR 72114  
P.O. BOX 5757, North Little Rock, AR 72119  
501-975-8881 Phone  
501-975-8885 Fax

### INVITATION TO BID/PROPOSAL COVER SHEET

Bid Number: 21-3723 Date Issued: Monday, August 2, 2021  
Date & Time Bid Opening: Tuesday, August 17, 2021

### Remount & Batesville Pike Guard Rail

Total Project Bid Price: \$ \_\_\_\_\_

Plans and specifications may be obtained from:

- Commerce Department at 120 Main Street, North Little Rock, AR 72114
- [www.nlr.ar.gov](http://www.nlr.ar.gov) click on the tab "Business," select "Bids and Vendors" and then choose "Current Bids."
- Please direct all technical questions in writing to David Cook at [dcook@nlr.ar.gov](mailto:dcook@nlr.ar.gov)
- General bid questions should be directed to the Commerce Department at 501-975-8881.

The City of North Little Rock encourages participation of small, minority, and woman own business enterprises in the procurement of goods, services, professional services, and construction, either as a general contractor or sub-contractor. It is further requested that whenever possible, majority contractors who require sub-contractors, seek qualified small, minority, and woman businesses to partner with them.

If you are obtaining this bid from our website, please be reminded that addendums may occur. It is therefore advisable that you review our listings for attachments including any changes to the bid.

**Note: FAILURE TO FILL OUT AND SIGN THE INVITATION TO BID SHEET WILL RESULT IN REJECTION OF THE BID.**

#### EXECUTION OF BID

Upon signing this page, the organization certifies that they have read and agree to the requirements set forth in this bid including conditions set forth and pertinent information requests.

Name of Firm: \_\_\_\_\_ Phone No.: \_\_\_\_\_

Arkansas Tax Permit No.: \_\_\_\_\_

Business Address: \_\_\_\_\_

Signature of Authorized Person: \_\_\_\_\_

Title: \_\_\_\_\_ Date: \_\_\_\_\_

PLEASE PUBLISH THE FOLLOWING LEGAL NOTICE ON:

Sunday, August 8, 2021

Notice to bidders  
Bid #21-3723

Notice is hereby given that the City of North Little Rock's Commerce Department will receive sealed proposals until, Tuesday, August 17, 2021 at 10:30am on the following:

## **REMOUNT & BATESVILLE PIKE GUARD RAIL**

---

### **1. NOTICE TO THE GENERAL CONTRACTORS**

Sealed bids for the **REMOUNT & BATESVILLE PIKE GUARD RAIL** will be received by the City of North Little Rock, at 10:30 am on Tuesday, August 17, 2021, at 120 Main Street, North Little Rock, Arkansas and then be publicly opened and read aloud. Any bids not submitted on time will be returned unopened.

### **2. SCOPE OF WORK**

The Contractor shall complete all work as specified or indicated in the Contract Documents. The work is generally described as follows: installation of Type A Guard Rail at three (3) locations along Remount Rd. and Batesville Pike.

### **3. SINGLE PROPOSAL**

Bidders shall submit one proposal for the entire project.

### **4. BID SUBMISSION**

Bids shall be submitted on the form within the project manual and shall be delivered in a clearly identified, sealed, opaque envelope prior to the date and time described above.

### **5. AVAILABILITY OF CONSTRUCTION DOCUMENTS**

Bona fide bidders may obtain documents at the address listed below, on the following basis:

- a. Drawings and Specifications may be examined at the following places:

COMMERCE DEPARTMENT  
120 Main Street  
North Little Rock, AR 72114  
(501) 975-8881  
Fax 975-8885

- a. [www.nlr.ar.gov](http://www.nlr.ar.gov) click on the tab “Business,” select “Bids and Vendors” and then choose “Current Bids.”

**6. BID SECURITY**

Bid security in the amount of five (5%) percent of the Base Proposal must accompany each proposal as described in the “Instruction to Bidders”.

**7. WITHDRAWAL OF BIDS**

No bid may be withdrawn for a period of sixty (60) days subsequent to date of the opening of Proposals and in accordance with the "Supplemental Instructions to Bidders" without consent of the Owner.

**8. COMPLIANCE WITH ARKANSAS STATUTES**

All bidders shall comply with the requirements of the Contractor’s Licensing Law of the State of Arkansas, and all applicable Arkansas regulations. All bonds on this project shall comply with Arkansas Statutory Performance and Payment Bond Law, Act 351 of 1953, as amended by Act 209 of 1957.

**9. REJECTION OF BIDS**

The Owner reserves the right to reject any or all bids and to waive any irregularities. Proposals which fail to comply fully with the provisions of the specifications and other Contract Documents will be considered invalid and may not receive consideration.

The right is reserved by the City of North Little Rock to reject any or all bids, in whole or part, or award items separately, or to waive informalities in bids received.

The City of North Little Rock encourages participation from MBE/DBE/WBE and SBA vendors.

**CITY OF NORTH LITTLE ROCK**

Amy Smith  
Assistant Director for Procurement

\*\*\*\*\*

Purchase Order No. \_\_\_\_\_

Send invoice and proof of publication to:

Amy Smith  
Commerce Department  
P.O. Box 5757  
North Little Rock, AR 72119

## GENERAL TERMS AND CONDITIONS FOR THE CITY OF NORTH LITTLE ROCK, AR

1. When submitting an "Invitation to Bid," the bidder warrants that the commodities covered by the bid shall be free from defects in material and workmanship under normal use and service. In addition, bidder must deliver new commodities of the latest design and model, unless otherwise specified in the "Invitation to Bid."
2. Prices quoted are to be net process, and when an error is made in extending total prices, the City may accept the bid for the lesser amount whether reflected by extension or by the correct multiple of the unit price.
3. Discounts offered will be taken when the City qualifies for such. The beginning date for computing discounts will be the date of invoice or the date of delivery and acceptance, whichever is later.
4. When bidding other than the brand and/or model specified in the "Invitation to Bid," the brand and/or model number must be stated by that item in the "Invitation to Bid," and descriptive literature be submitted with the bid.
5. The City reserves the right to reject any and all bids.
6. The Purchasing office reserves the right to award items, all or none, or by line item(s).
7. Quality, time and probability of performance may be factors in making an award.
8. Bid quotes submitted will remain firm for 30 calendar days from bid opening date; however, the prices may remain firm for a longer period of time if mutually agreeable between bidder and the Department of Commerce.
9. Bidder must submit a completed signed copy of the front page of the "Invitation to Bid" and must submit any other information required in the "Invitation to Bid."
10. In the event a contract is entered into pursuant to the "Invitation to Bid," the bidder shall not discriminate against any qualified employee or qualified applicant for employment because of race, sex, color, creed, national origin or ancestry. The bidder must include in any and all subcontracts a provision similar to the above.
11. Sales or use tax is not to be included in the bid price, but is to be added by the vendor to the invoice billing to the City. Although use tax is not to be included in this bid, vendors are to register and pay tax direct to the Arkansas State Revenue Department.
12. Prices quoted shall be "Free on Board" (F.O.B.) to destination at designated facility in North Little Rock. Charges may not be added after the bid is opened.
13. In the event of two or more identical low bids, the contract may be awarded arbitrarily or for any reason to any of such bidders or split in any proportion between them at the discretion of the Department of Commerce..
14. Specifications furnished with this Invitation are intended to establish a desired quality or performance level, or other minimum dimensions and capacities, which will provide the best product available at the lowest possible price. Other than designated brands and/or models approved as equal to designated products shall receive an equal consideration.
15. Samples of items when required, must be furnished free, and, if not called for within 30 days from date of bid opening, will become property of the City.
16. Bids will not be considered if they are:
  1. Submitted after the bid's opening time.
  2. Submitted electronically or faxed (unless authorized by Purchasing Agent).

17. Guarantees and warranties should be submitted with the bid, as they may be a consideration in making an award.
18. **CONSTRUCTION**
  - A. Contractor is to supply the City with evidence of having and maintaining proper and complete insurance, specifically Workman's Compensation Insurance in accordance with the laws of the State of Arkansas, Public Liability and Property Damage. All premiums and cost shall be paid by the Contractor. In no way will the City be responsible in case of accident.
  - B. When noted, a Certified check or bid bond in the amount of 5% of total bid shall accompany bid.
  - C. A Performance Bond equaling the total amount of any bid exceeding \$20,000.00 must be provided for any contract for the repair, alteration or erection of any public building, public structure or public improvement (pursuant to Arkansas Code Annotated Section 22-9-203).
19. **LIQUIDATED DAMAGES** - Liquidated damages shall be assessed beginning on the first day following the maximum delivery or completion time entered on this bid form and/or provided for by the plans and specifications.
20. **AMBIGUITY IN BID** - Any ambiguity in any bid as the result of omission, error, lack of clarity or non-compliance by the bidder with specifications, instructions, and all conditions of bidding shall be construed in the light most favorable to the City.
21. The bid number should be stated on the face of the sealed bid envelope. If it is not, the envelope will have to be opened to identify.
22. Whenever a bid is sought seeking a source of supply for a specified period of time for materials and services, the quantities of usage shown are estimated ONLY. No guarantee or warranty is given or implied by the participants as to the total amount that may or may not be purchased from any resulting contracts. These quantities are for the bidders information ONLY and will be used for tabulation and presentation of bid and the participant reserves the right to increase or decrease quantities as required.
23. The City of North Little Rock reserves the right to reject any and all bids, to accept in whole or in part, to waive any informalities in bids received, to accept bids on materials or equipment with variations from specifications in those cases where efficiency of operation will not be impaired, and unless otherwise specified by the bidder, to accept any item in the bid. If unit prices and extensions thereof do not coincide, the City of North Little Rock may accept the bid for the lesser amount whether reflected by the extension or by the correct multiple of the unit price.
24. Additional information or bid forms may be obtained from:  
COMMERCE DEPARTMENT, 120 Main Street, P.O. Box 5757, North Little Rock, Arkansas 72119 (501)975-8881  
[www.nlr.ar.gov](http://www.nlr.ar.gov)

**Bidding documents must be submitted on or before the bid's opening date and time. Unless noted, bids must be sealed and mailed or delivered to:**

Mary Beth Bowman  
Director of Commerce  
120 Main Street (P.O. Box 5757)  
North Little Rock, AR 72119



**BID FORM**

**NOTE TO BIDDER:** Please use BLACK ink for completing this Bid form.

To. \_\_\_\_\_  
Address: \_\_\_\_\_  
\_\_\_\_\_

Project Title: **REMOUNT & BATESVILLE PIKE GUARD RAIL**

Engineer's  
Project No.: **CNLR ENGINEERING PROJECT NO. 21-24**

Date: \_\_\_\_\_ Arkansas Contractor's  
License No.: \_\_\_\_\_

Bidder: \_\_\_\_\_

Address: \_\_\_\_\_

Bidder's person to contact for additional information on this Bid:

Name: \_\_\_\_\_

Telephone: \_\_\_\_\_

**ADDENDA**

The Bidder hereby acknowledges that he/she has received Addenda Numbers:

\_\_\_\_\_ to these Specifications.  
(Bidder insert number of each addendum received.)

**CONSTRUCTION DAYS**

The Work will be completed and ready for final payment in accordance with the General Conditions within **45 Calendar Days** after the date when the Contract Time commences to run as provided in Notice to Proceed.

**LIQUIDATED DAMAGES**

Liquidated Damages: Owner and Contractor recognize that time is of the essence of this Agreement and the Owner will suffer financial loss if the Work is not completed within the time specified in above, plus any extensions thereof allowed in accordance with the General Conditions. They also recognize the delays, expense, and difficulties involved in proving the actual loss suffered by Owner if the Work is not completed on time. Accordingly, instead of requiring any such proof, Owner and Contractor agree that as liquidated damages for delay (but not as a penalty) Contractor shall pay Owner **Two Hundred and Fifty Dollars (\$250.00)** for each day that expires after the time specified in Paragraph 3 for completion and readiness for final payment.

## **INSURANCE AND BONDING REQUIREMENTS**

The Bidder hereby acknowledges that he/she has read and understands the performance bond, payment bond, and insurance requirements for this project as specified in the General Conditions. If awarded a construction contract, the Bidder agrees to furnish the required bonds and insurance certificates within fifteen (15) days of the date the award is made.

Signature \_\_\_\_\_ Title \_\_\_\_\_

## **BIDDER'S DECLARATION AND UNDERSTANDING**

The undersigned, hereinafter called the Bidder, declares that the only persons or parties interested in this Bid are those named herein, that this Bid is, in all respects, fair and without fraud, that it is made without collusion with any official of the Owner, and that the Bid is made without any connection or collusion with any person submitting another Bid on this Contract.

The Bidder further declares that he has carefully examined the Contract Documents for the construction of the project, that he has personally inspected the site, that he has satisfied himself as to the quantities involved, including materials and equipment, and conditions of work involved, including the fact that the description of the quantities of work and materials, as included herein, is brief and is intended only to indicate the general nature of the work and to identify the said quantities with the detailed requirements of the Contract Documents, and that this Bid is made according to the provisions and under the terms of the Contract Documents, which Documents are hereby made a part of this Bid.

The Bidder further agrees that he has exercised his own judgment and has utilized all data which he believes pertinent from the Engineer, Owner, and other sources in arriving at his own conclusions.

The Bidder states that he has experience in and is qualified to perform the work herein specified and, if he does not have craftsmen experienced and qualified in any phase of the work for which this Bid is offered, that he will subcontract the work under said phase to a contractor who does have the necessary experience and qualifications.

## **CONTRACT EXECUTION AND BONDS**

The Bidder agrees that if this Bid is accepted, he will, within 15 days after notice of award, sign the Contract in the form annexed hereto, and will at that time, deliver to the Owner the Performance Bond and Payment Bond required herein, and will, to the extent of his Bid, furnish all machinery, tools, apparatus, and other means of construction and do the work and furnish all the materials necessary to complete all work as specified or indicated in the Contract Documents.

## **CERTIFICATES OF INSURANCE, PAYMENT BOND, AND PERFORMANCE BOND**

The Bidder further agrees to furnish the Owner, before executing the Contract, the certificates of insurance, Payment Bond, and Performance Bond as specified in these Documents.

## **START OF CONSTRUCTION, CONTRACT COMPLETION TIME, AND LIQUIDATED DAMAGES**

Start of Construction, Contract Completion Time, and Liquidated Damages are stated in Document 00500 - Contract.

**SALES AND USE TAXES**

The Bidder agrees that all federal, state, and local sales and use taxes are included in the stated bid prices for the work.

**LUMP SUM BASE BID**

Any Bid may be rejected which contains material omissions, or irregularities, or in which any of the unit prices are obviously unbalanced in the opinion of the Owner. Also, a bid may be rejected if, in any manner it shall fail to conform to the conditions of the published Bidding Requirements and Contract Documents.

The bidder agrees to accept as full payment for the work proposed herein the amount computed under the provisions of the Contract Documents and based on the following lump sum amount. The bidder agrees that the lump sum price represents a true measure of the labor and materials required to perform the work, including all allowances for overhead and profit for each type and unit of work called for in the Contract Documents.

**TOTAL BASE BID AMOUNT \$** \_\_\_\_\_

\_\_\_\_\_  
**Words**

**BASIS OF AWARD**

The Bidder understands that the Contract will be awarded to the most qualified bidder with the lowest Total Base Bid that the Owner may choose that makes the Project cost acceptable to the Owner. The Owner reserves the right to waive irregularities, reject bids, choose the most qualified bidder for the Project, and to postpone award of the Contract for a period of time which shall not exceed beyond 90 days from the bid opening date.

**PAYMENT SCHEDULE**

A detailed payment schedule for each structure or unit shall be submitted by the successful low Bidder. The successful low Bidder shall meet with the Engineer and Owner in North Little Rock, Arkansas, to review the format and details of the payment schedule. This meeting shall be held within 5 days of notification that the Contractor is the low Bidder. The purpose of the meeting shall be to establish an acceptable format for the payment schedule. The construction detailed payment schedule shall be completed by the Contractor 14 days after the meeting and submitted to the Engineer and Owner for review and approval. Failure of the Contractor to submit the payment schedule as required may result in the Owner's rejection of the Bid or delay in processing the Contractor's request for a progress payment.

**SUBCONTRACTORS**

The Bidder further certifies that proposals from the following subcontractors were used in the preparation of this Bid; and if awarded a contract, Bidder agrees to not enter into Contracts with others for these divisions of the Work without written approval from the Owner and Engineer.

\_\_\_\_\_  
**Subcontractor**  
\_\_\_\_\_

\_\_\_\_\_  
**Subcontractor**  
\_\_\_\_\_

---

Arkansas Contractor License #

---

Street Address, City, State, Zip Code

---

**Subcontractor**

---

Arkansas Contractor License #

---

Street Address, City, State, Zip Code

---

Arkansas Contractor License #

---

Street Address, City, State, Zip Code

---

**Subcontractor**

---

Arkansas Contractor License #

---

Street Address, City, State, Zip Code

**SUPPLIERS/VENDORS**

The Bidder shall list the suppliers/vendors where material for this Project will be purchased from and successful Bidder shall updated suppliers/vendors during construction of the Project.

---

**Supplier/Vendor Name**

---

Street Address, City, State, Zip Code

---

Phone Number

---

**Supplier/Vendor Name**

---

Street Address, City, State, Zip Code

---

Phone Number

---

**Supplier/Vendor Name**

---

Street Address, City, State, Zip Code

---

Phone Number

---

**Supplier/Vendor Name**

---

Street Address, City, State, Zip Code

---

Phone Number

**PERFORMANCE OF WORK BY CONTRACTOR**

The Bidder shall perform at least 40 percent of the work with his own forces (refer to Paragraph 24, INSTRUCTIONS TO BIDDERS. Bids from so called "Brokerage Contractors" will not be considered.) List below the items that the Bidder will perform with his own forces, if awarded this Contract, and fill in the blank showing the estimated total cost of these items.

---



---



---



---



---

Estimated total cost of the above items the Bidder states that will be performed with his own forces, if awarded Contract:

\_\_\_\_\_ Dollars (\$ \_\_\_\_\_ )  
 (Words)

**EXPERIENCE OF BIDDER**

The Bidder states that he is an experienced Contractor and has completed similar projects within the last 5 years. (List similar projects, with types, names of clients, construction costs, and references with telephone numbers. Use additional sheets if necessary.)

---

---

---

---

---

**SURETY**

If the Bidder is awarded a construction Contract on this Bid, the Surety who provides the Performance and Payment Bond will be:

\_\_\_\_\_ whose address is:

\_\_\_\_\_  
Street, City, State Zip Code

**BIDDER**

The name of the Bidder submitting this Bid is:

\_\_\_\_\_ doing business at:

\_\_\_\_\_  
Street, City, State, Zip Code

which is the address to which all communications concerned with this Bid and with the Contract shall be sent.

The names of the principal officers of the corporation submitting this Bid, or of the partnership, or of all persons interested in this Bid as principals are as follows:

---

---

---

**If Sole Proprietor or Partnership**

IN WITNESS hereto the undersigned has set his (its) hand this \_\_\_\_ day of \_\_\_\_\_, 20\_\_.

\_\_\_\_\_  
Signature of Bidder

\_\_\_\_\_  
Title

**If Corporation**

IN WITNESS WHEREOF the undersigned corporation has caused this instrument to be executed and its seal affixed by its duly authorized officers this \_\_\_\_ day of \_\_\_\_\_, 20\_\_.

\_\_\_\_\_  
Name of Corporation

By \_\_\_\_\_

Title \_\_\_\_\_

Attest \_\_\_\_\_

Secretary

(SEAL)

**BID BOND**

**STATE OF ARKANSAS**

**KNOW ALL MEN BY THESE PRESENTS**, that we:

\_\_\_\_\_  
Principal and Contractor, and \_\_\_\_\_

\_\_\_\_\_  
hereinafter called Surety, are held and firmly bound unto the **City of** \_\_\_\_\_, **Arkansas** and represented by its Mayor and City Council, hereinafter called Owner, in the sum of

\_\_\_\_\_ DOLLARS (\$\_\_\_\_\_)

lawful money of the United States of America, for the payment of which well and truly to be made, we bind ourselves, our heirs, executors, administrators, successors and assigns, jointly and severally, by these presents.

**WHEREAS**, the Principal contemplates submitting or has submitted a bid to the Owner for the furnishing of all labor, materials (except those to be specifically furnished by the Owner), equipment, machinery, tools, apparatus, means of transportation for, and the performance of the work covered in the Bid and the detailed Drawings and Specifications, entitled:

**REMOUNT & BATESVILLE PIKE GUARD RAIL  
City Engineering Project No. 21-24  
North Little Rock, Arkansas**

**WHEREAS**, it was a condition precedent to the submission of said bid that a cashier's check, certified check, or bid bond in the amount of 5 percent of the base bid be submitted with said bid as a guarantee that the Bidder would, if awarded the Contract, enter into a written Contract with the Owner for the performance of said Contract within 15 consecutive calendar days after written notice having been given of the award of the Contract.

**NOW, THEREFORE**, the conditions of this obligation are such that if the Principal within 15 consecutive calendar days after written notice of such acceptance enters into a written Contract with the Owner and furnishes a Contract Surety Bond in an amount equal to 100 percent of the base bid, satisfactory to the Owner, then this obligation shall be void; otherwise the sum herein stated shall be due and payable to the Owner and the Surety herein agrees to pay said sum immediately upon demand of the Owner in good and lawful money of the United States of America, as liquidated damages for failure thereof of said Principal.

**IN WITNESS WHEREOF**, the said \_\_\_\_\_, as Principal herein,  
has caused these presents to be signed in its name by its \_\_\_\_\_  
and attested by its \_\_\_\_\_ under its corporate seal, and the  
said \_\_\_\_\_ as Surety herein, has caused  
these presents to be signed in its name by its \_\_\_\_\_  
\_\_\_\_\_ under its corporate seal, this \_\_\_\_\_ day of \_\_\_\_\_ A.D., 20\_\_.

Signed, sealed and delivered  
in the presence of:

\_\_\_\_\_  
Principal-Contractor

By \_\_\_\_\_

\_\_\_\_\_  
As to Principal

\_\_\_\_\_  
Title

Surety

\_\_\_\_\_  
Attorney-in-Fact  
(Power-of-Attorney to be Attached)

\_\_\_\_\_  
As to Surety

By \_\_\_\_\_  
Agent



## NOTICE OF AWARD

**TO:**

**PROJECT:     REMOUNT & BATESVILLE PIKE GUARD RAIL**  
**City Project No. 21-24**

The OWNER has considered the BID submitted by you on \_\_\_\_\_ for the above described WORK in response to its Advertisement for Bids and Instructions to Bidders.

You are hereby notified that your BID has been accepted in the amount of:  
\_\_\_\_\_ Dollars (\$ \_\_\_\_\_)

You are required by the Instructions to Bidders to execute the Contract and furnish the required CONTRACTOR'S Performance BOND, Payment BOND, and certificates of insurance within fifteen (15) calendar days from the date of this Notice to you.

If you fail to execute said Contract and to furnish said BONDS within fifteen (15) days from the date of this Notice, said OWNER will be entitled to consider your bid in default, to annul this Notice of Award and to declare your Bid Security forfeited. The OWNER will be entitled to such other rights as may be granted by law.

You are required to return an acknowledged copy of this NOTICE OF AWARD to the OWNER.

Dated this \_\_\_\_\_ day of \_\_\_\_\_.

Owner

By \_\_\_\_\_

Title     City Engineer

### ACCEPTANCE OF NOTICE

Receipt of the above NOTICE OF AWARD is hereby acknowledged

by \_\_\_\_\_,

this the \_\_\_\_\_ day of \_\_\_\_\_, 20

By \_\_\_\_\_

Title \_\_\_\_\_

# PERFORMANCE BOND

Any singular reference to Contractor, Surety, Owner, or other party shall be considered plural where applicable.

---

CONTRACTOR (*Name and Address*):                      SURETY (*Name, and Address of Principal Place of Business*):

OWNER (*Name and Address*):

## CONTRACT

Effective Date of Agreement:  
Amount:  
Description (*Name and Location*):

## BOND

Bond Number:  
Date (*Not earlier than Effective Date of Agreement*):  
Amount:  
Modifications to this Bond Form:

Surety and Contractor, intending to be legally bound hereby, subject to the terms set forth below, do each cause this Performance Bond to be duly executed by an authorized officer, agent, or representative.

## CONTRACTOR AS PRINCIPAL

## SURETY

\_\_\_\_\_  
Contractor's Name and Corporate Seal (Seal)

\_\_\_\_\_  
Surety's Name and Corporate Seal (Seal)

By: \_\_\_\_\_  
Signature

By: \_\_\_\_\_  
Signature (Attach Power of Attorney)

\_\_\_\_\_  
Print Name

\_\_\_\_\_  
Print Name

\_\_\_\_\_  
Title

\_\_\_\_\_  
Title

Attest: \_\_\_\_\_  
Signature

Attest: \_\_\_\_\_  
Signature

\_\_\_\_\_  
Title

\_\_\_\_\_  
Title

*Note: Provide execution by additional parties, such as joint ventures, if necessary.*

Contractor and Surety, jointly and severally, bind themselves, their heirs, executors, administrators, successors, and assigns to Owner for the performance of the Contract, which is incorporated herein by reference.

1. If Contractor performs the Contract, Surety and Contractor have no obligation under this Bond, except to participate in conferences as provided in Paragraph 2.1.
2. If there is no Owner Default, Surety's obligation under this Bond shall arise after:
  - 2.1 Owner has notified Contractor and Surety, at the addresses described in Paragraph 9 below, that Owner is considering declaring a Contractor Default and has requested and attempted to arrange a conference with Contractor and Surety to be held not later than 15 days after receipt of such notice to discuss methods of performing the Contract. If Owner, Contractor, and Surety agree, Contractor shall be allowed a reasonable time to perform the Contract, but such an agreement shall not waive Owner's right, if any, subsequently to declare a Contractor Default; and
  - 2.2 Owner has declared a Contractor Default and formally terminated Contractor's right to complete the Contract. Such Contractor Default shall not be declared earlier than 20 days after Contractor and Surety have received notice as provided in Paragraph 2.1; and
  - 2.3 Owner has agreed to pay the Balance of the Contract Price to:
    1. Surety in accordance with the terms of the Contract; or
    2. Another contractor selected pursuant to Paragraph 3.3 to perform the Contract.
3. When Owner has satisfied the conditions of Paragraph 2, Surety shall promptly, and at Surety's expense, take one of the following actions:
  - 3.1 Arrange for Contractor, with consent of Owner, to perform and complete the Contract; or
  - 3.2 Undertake to perform and complete the Contract itself, through its agents or through independent contractors; or
  - 3.3 Obtain bids or negotiated proposals from qualified contractors acceptable to Owner for a contract for performance and completion of the Contract, arrange for a contract to be prepared for execution by Owner and contractor selected with Owner's concurrence, to be secured with performance and payment bonds executed by a qualified surety equivalent to the bonds issued on the Contract, and pay to Owner the amount of damages as described in Paragraph 5 in excess of the Balance of the Contract Price incurred by Owner resulting from Contractor Default; or
  - 3.4 Waive its right to perform and complete, arrange for completion, or obtain a new contractor, and with reasonable promptness under the circumstances:
    1. After investigation, determine the amount for which it may be liable to Owner and, as soon as practicable after the amount is determined, tender payment therefor to Owner; or
    2. Deny liability in whole or in part and notify Owner citing reasons therefor.
4. If Surety does not proceed as provided in Paragraph 3 with reasonable promptness, Surety shall be deemed to be in default on this Bond 15 days after receipt of an additional written notice from Owner to Surety demanding that Surety perform its obligations under this Bond, and Owner shall be entitled to enforce any remedy available to Owner. If Surety proceeds as provided in Paragraph 3.4, and Owner refuses the payment tendered or Surety has denied liability, in whole or in part, without further notice Owner shall be entitled to enforce any remedy available to Owner.
5. After Owner has terminated Contractor's right to complete the Contract, and if Surety elects to act under Paragraph 3.1, 3.2, or 3.3 above, then the responsibilities of Surety to Owner shall not be greater than those of Contractor under the Contract, and the responsibilities of Owner to Surety shall not be greater than those of Owner under the Contract. To the limit of the amount of this Bond, but subject to commitment by Owner of the Balance of the Contract Price to mitigation of costs and damages on the Contract, Surety is obligated without duplication for:

- 5.1 The responsibilities of Contractor for correction of defective Work and completion of the Contract;
- 5.2 Additional legal, design professional, and delay costs resulting from Contractor's Default, and resulting from the actions of or failure to act of Surety under Paragraph 3; and
- 5.3 Liquidated damages, or if no liquidated damages are specified in the Contract, actual damages caused by delayed performance or non-performance of Contractor.

6. Surety shall not be liable to Owner or others for obligations of Contractor that are unrelated to the Contract, and the Balance of the Contract Price shall not be reduced or set off on account of any such unrelated obligations. No right of action shall accrue on this Bond to any person or entity other than Owner or its heirs, executors, administrators, or successors.

7. Surety hereby waives notice of any change, including changes of time, to Contract or to related subcontracts, purchase orders, and other obligations.

8. Any proceeding, legal or equitable, under this Bond may be instituted in any court of competent jurisdiction in the location in which the Work or part of the Work is located, and shall be instituted within two years after Contractor Default or within two years after Contractor ceased working or within two years after Surety refuses or fails to perform its obligations under this Bond, whichever occurs first. If the provisions of this paragraph are void or prohibited by law, the minimum period of limitation available to sureties as a defense in the jurisdiction of the suit shall be applicable.

9. Notice to Surety, Owner, or Contractor shall be mailed or delivered to the address shown on the signature page.

10. When this Bond has been furnished to comply with a statutory requirement in the location where the Contract was to be performed, any provision in this Bond conflicting with said statutory requirement shall be deemed deleted herefrom and provisions conforming to such statutory requirement shall be deemed incorporated herein. The intent is that this Bond shall be construed as a statutory bond and not as a common law bond.

11. Definitions.

- 11.1 Balance of the Contract Price: The total amount payable by Owner to Contractor under the Contract after all proper adjustments have been made, including allowance to Contractor of any amounts received or to be received by Owner in settlement of insurance or other Claims for damages to which Contractor is entitled, reduced by all valid and proper payments made to or on behalf of Contractor under the Contract.
- 11.2 Contract: The agreement between Owner and Contractor identified on the signature page, including all Contract Documents and changes thereto.
- 11.3 Contractor Default: Failure of Contractor, which has neither been remedied nor waived, to perform or otherwise to comply with the terms of the Contract.
- 11.4 Owner Default: Failure of Owner, which has neither been remedied nor waived, to pay Contractor as required by the Contract or to perform and complete or otherwise comply with the other terms thereof.

FOR INFORMATION ONLY – *(Name, Address and Telephone)*  
Surety Agency or Broker:  
Owner's Representative *(Engineer or other party)*:

## PAYMENT BOND

CONTRACTOR *(name and address)*:

SURETY *(name and address of principal place of business)*:

OWNER *(name and address)*:

### CONSTRUCTION CONTRACT

Effective Date of the Agreement:

Amount:

Description *(name and location)*:

### BOND

Bond Number:

Date *(not earlier than the Effective Date of the Agreement of the Construction Contract)*:

Amount:

Modifications to this Bond Form:  None  See Paragraph 18

---

Surety and Contractor, intending to be legally bound hereby, subject to the terms set forth below, do each cause this Payment Bond to be duly executed by an authorized officer, agent, or representative.

### CONTRACTOR AS PRINCIPAL

### SURETY

\_\_\_\_\_ *(seal)*

Contractor's Name and Corporate Seal

\_\_\_\_\_ *(seal)*

Surety's Name and Corporate Seal

By: \_\_\_\_\_  
Signature

By: \_\_\_\_\_  
Signature *(attach power of attorney)*

\_\_\_\_\_  
Print Name

\_\_\_\_\_  
Print Name

\_\_\_\_\_  
Title

\_\_\_\_\_  
Title

Attest: \_\_\_\_\_  
Signature

Attest: \_\_\_\_\_  
Signature

\_\_\_\_\_  
Title

\_\_\_\_\_  
Title

**Notes:** (1) Provide supplemental execution by any additional parties, such as joint venturers. (2) Any singular reference to Contractor, Surety, Owner, or other party shall be considered plural where applicable.

1. The Contractor and Surety, jointly and severally, bind themselves, their heirs, executors, administrators, successors, and assigns to the Owner to pay for labor, materials, and equipment furnished for use in the performance of the Construction Contract, which is incorporated herein by reference, subject to the following terms.
2. If the Contractor promptly makes payment of all sums due to Claimants, and defends, indemnifies, and holds harmless the Owner from claims, demands, liens, or suits by any person or entity seeking payment for labor, materials, or equipment furnished for use in the performance of the Construction Contract, then the Surety and the Contractor shall have no obligation under this Bond.
3. If there is no Owner Default under the Construction Contract, the Surety's obligation to the Owner under this Bond shall arise after the Owner has promptly notified the Contractor and the Surety (at the address described in Paragraph 13) of claims, demands, liens, or suits against the Owner or the Owner's property by any person or entity seeking payment for labor, materials, or equipment furnished for use in the performance of the Construction Contract, and tendered defense of such claims, demands, liens, or suits to the Contractor and the Surety.
4. When the Owner has satisfied the conditions in Paragraph 3, the Surety shall promptly and at the Surety's expense defend, indemnify, and hold harmless the Owner against a duly tendered claim, demand, lien, or suit.
5. The Surety's obligations to a Claimant under this Bond shall arise after the following:
  - 5.1 Claimants who do not have a direct contract with the Contractor,
    - 5.1.1 have furnished a written notice of non-payment to the Contractor, stating with substantial accuracy the amount claimed and the name of the party to whom the materials were, or equipment was, furnished or supplied or for whom the labor was done or performed, within ninety (90) days after having last performed labor or last furnished materials or equipment included in the Claim; and
    - 5.1.2 have sent a Claim to the Surety (at the address described in Paragraph 13).
  - 5.2 Claimants who are employed by or have a direct contract with the Contractor have sent a Claim to the Surety (at the address described in Paragraph 13).
6. If a notice of non-payment required by Paragraph 5.1.1 is given by the Owner to the Contractor, that is sufficient to satisfy a Claimant's obligation to furnish a written notice of non-payment under Paragraph 5.1.1.
7. When a Claimant has satisfied the conditions of Paragraph 5.1 or 5.2, whichever is applicable, the Surety shall promptly and at the Surety's expense take the following actions:
  - 7.1 Send an answer to the Claimant, with a copy to the Owner, within sixty (60) days after receipt of the Claim, stating the amounts that are undisputed and the basis for challenging any amounts that are disputed; and
  - 7.2 Pay or arrange for payment of any undisputed amounts.
  - 7.3 The Surety's failure to discharge its obligations under Paragraph 7.1 or 7.2 shall not be deemed to constitute a waiver of defenses the Surety or Contractor may have or acquire as to a Claim, except as to undisputed amounts for which the Surety and Claimant have reached agreement. If, however, the Surety fails to discharge its obligations under Paragraph 7.1 or 7.2, the Surety shall indemnify the Claimant for the reasonable attorney's fees the Claimant incurs thereafter to recover any sums found to be due and owing to the Claimant.
8. The Surety's total obligation shall not exceed the amount of this Bond, plus the amount of reasonable attorney's fees provided under Paragraph 7.3, and the amount of this Bond shall be credited for any payments made in good faith by the Surety.
9. Amounts owed by the Owner to the Contractor under the Construction Contract shall be used for the performance of the Construction Contract and to satisfy claims, if any, under any construction performance bond. By the Contractor furnishing and the Owner accepting this Bond, they agree that all funds earned by the Contractor in the performance of the Construction Contract are dedicated to satisfy obligations of the Contractor and Surety under this Bond, subject to the Owner's priority to use the funds for the completion of the work.
10. The Surety shall not be liable to the Owner, Claimants, or others for obligations of the Contractor that are unrelated to the Construction Contract. The Owner shall not be liable for the payment of any costs or expenses of any Claimant under this Bond, and shall have under this Bond no obligation to make payments to or give notice on behalf of Claimants, or otherwise have any obligations to Claimants under this Bond.
11. The Surety hereby waives notice of any change, including changes of time, to the Construction Contract or to related subcontracts, purchase orders, and other obligations.
12. No suit or action shall be commenced by a Claimant under this Bond other than in a court of competent jurisdiction in the state in which the project that is the subject of the Construction Contract is located or after the expiration of one year from the date (1) on which the Claimant sent a Claim to the Surety pursuant to Paragraph 5.1.2 or 5.2, or

(2) on which the last labor or service was performed by anyone or the last materials or equipment were furnished by anyone under the Construction Contract, whichever of (1) or (2) first occurs. If the provisions of this paragraph are void or prohibited by law, the minimum period of limitation available to sureties as a defense in the jurisdiction of the suit shall be applicable.

13. Notice and Claims to the Surety, the Owner, or the Contractor shall be mailed or delivered to the address shown on the page on which their signature appears. Actual receipt of notice or Claims, however accomplished, shall be sufficient compliance as of the date received.
14. When this Bond has been furnished to comply with a statutory or other legal requirement in the location where the construction was to be performed, any provision in this Bond conflicting with said statutory or legal requirement shall be deemed deleted herefrom and provisions conforming to such statutory or other legal requirement shall be deemed incorporated herein. When so furnished, the intent is that this Bond shall be construed as a statutory bond and not as a common law bond.
15. Upon requests by any person or entity appearing to be a potential beneficiary of this Bond, the Contractor and Owner shall promptly furnish a copy of this Bond or shall permit a copy to be made.

## 16. Definitions

16.1 **Claim:** A written statement by the Claimant including at a minimum:

1. The name of the Claimant;
2. The name of the person for whom the labor was done, or materials or equipment furnished;
3. A copy of the agreement or purchase order pursuant to which labor, materials, or equipment was furnished for use in the performance of the Construction Contract;
4. A brief description of the labor, materials, or equipment furnished;
5. The date on which the Claimant last performed labor or last furnished materials or equipment for use in the performance of the Construction Contract;
6. The total amount earned by the Claimant for labor, materials, or equipment furnished as of the date of the Claim;
7. The total amount of previous payments received by the Claimant; and
8. The total amount due and unpaid to the Claimant for labor, materials, or equipment furnished as of the date of the Claim.

16.2 **Claimant:** An individual or entity having a direct contract with the Contractor or with a subcontractor of the Contractor to furnish labor, materials, or equipment for use in the performance of the Construction Contract. The term Claimant also includes any individual or entity that has rightfully asserted a claim under an applicable mechanic's lien or similar statute against the real property upon which the Project is located. The intent of this Bond

shall be to include without limitation in the terms of "labor, materials, or equipment" that part of the water, gas, power, light, heat, oil, gasoline, telephone service, or rental equipment used in the Construction Contract, architectural and engineering services required for performance of the work of the Contractor and the Contractor's subcontractors, and all other items for which a mechanic's lien may be asserted in the jurisdiction where the labor, materials, or equipment were furnished.

16.3 **Construction Contract:** The agreement between the Owner and Contractor identified on the cover page, including all Contract Documents and all changes made to the agreement and the Contract Documents.

16.4 **Owner Default:** Failure of the Owner, which has not been remedied or waived, to pay the Contractor as required under the Construction Contract or to perform and complete or comply with the other material terms of the Construction Contract.

16.5 **Contract Documents:** All the documents that comprise the agreement between the Owner and Contractor.

17. If this Bond is issued for an agreement between a contractor and subcontractor, the term Contractor in this Bond shall be deemed to be Subcontractor and the term Owner shall be deemed to be Contractor.

18. Modifications to this Bond are as follows:



## **CONTRACT**

### **FOR**

## **REMOUNT & BATESVILLE PIKE GUARD RAIL**

**THIS CONTRACT**, by and between the City of North Little Rock (“City”), acting herein through its Mayor, Terry C. Hartwick, and \_\_\_\_\_ (“Contractor”), is effective on the date signed by the City (the “Effective Date”).

In consideration of the mutual covenants herein, the parties agree as follows:

### **ARTICLE 1. SCOPE OF WORK**

#### 1.1 Work

A. The Contractor shall complete all Work as specified or indicated in the Contract Documents. The Work generally is described as follows:

Installation of Type A guard rail at three (3) locations along Remount Road and Batesville Pike.

B. All Contract Documents, including plans and specifications, are included in the Project Manual, which is incorporated herein by reference as Exhibit “A.”

C. The Work includes but is not limited to, all labor, materials, equipment, supplies, and incidental items necessary to complete the Project in conformance with the plans and specifications as more fully set forth in the Contract Documents (the “Project”). The Work may include related services such as testing, start-up, and commissioning, all as required by the Contract Documents.

### **ARTICLE 2. CONTRACT DOCUMENTS**

#### 2.1 Intent of Contract Documents

A. It is the intent of the Contract Documents to describe a functionally complete project. The Contract Documents do not indicate or describe all of the Work required to complete the



Project. Additional details required for the correct installation of selected products are to be provided by the Contractor and coordinated with the City and Engineer. This Contract supersedes prior negotiations, representations, and agreements, whether written or oral. The Contract Documents are complementary; what is required by one part of the Contract Documents is as binding as if required by other parts of the Contract Documents.

B. During the performance of the Work and until final payment, Contractor and City shall submit all matters in question concerning the requirements of the Contract Documents, or relating to the acceptability of the Work under the Contract Documents to the Engineer. Engineer will be the initial interpreter of the requirements of the Contract Documents, and judge of the acceptability of the Work thereunder.

C. Engineer will render a written clarification, interpretation, or decision on the issue submitted, or initiate a modification to the Contract Documents.

D. Contractor, and its subcontractors and suppliers, shall not have or acquire any title to or ownership rights to any of the Drawings, Specifications, or other documents (including copies or electronic media editions) prepared by Engineer or its consultants.

## 2.2 Contract Documents Defined

A. The Contract Documents shall consist of the following documents:

- .1 The fully executed Contract; which incorporates by reference documents (.2) thru (.10).
- .2 The Invitation to Bid, *sans* the bidding requirements dated: \_\_\_\_\_
- .3 The Contractor's Bid dated: \_\_\_\_\_, including any attachments
- .4 Project Manual, which contains General Requirements, and applicable Drawings and Specifications (Exhibit A);
- .5 Performance, Maintenance and Payment Bond;
- .6 Certificate of Insurance Coverage

The following, which may be delivered or issued on or after the Effective Date of the Contract and are, not attached hereto:

- .7 Written Amendments;
- .8 Work Change Directives;
- .9 Change Order(s); and
- .10 Notice to Proceed.

To the extent of any direct conflict between any of the Contract Documents, the Contractor shall immediately seek clarification from the Engineer. In the event that the Engineer fails promptly to

clarify such discrepancy, the Contractor shall proceed with the Work and give precedence to the Contract Documents in the following order of priority:

- .1 Modifications issued after execution of this Agreement;
- .2 This Agreement, as modified;
- .3 Addenda issued prior to the execution of the Agreement, with the Addenda bearing the latest date taking precedence;
- .4 Any Supplementary Conditions, if applicable;
- .5 The General Conditions of the Contract for Construction, as modified;
- .6 The Drawings and Specifications; and
- .7 Other documents specifically enumerated in the Agreement as part of the Contract Documents.

2.3 The Contract Documents may only be amended, modified, or supplemented by a Change Order, a Work Change Directive or a Field Order. If an amendment or supplement to the Contract includes a change in the Contract Price or the Contract Times, such amendment or supplement must be set forth in a Change Order. All changes to the Contract that involve (1) the performance or acceptability of the Work, (2) the design (as set forth in the Drawings, Specifications, or otherwise), or (3) other engineering or technical matters, must be supported by Engineer's recommendation.

### **ARTICLE 3 ENGINEER**

3.1 The Project will be coordinated by:

City of North Little Rock Engineering Department

David Cook (City Engineer)

Who is hereinafter called ENGINEER, and who is to act as City's representative, assumes all duties and responsibilities, and has the rights and authority assigned to ENGINEER in the Contract Documents.

### **ARTICLE 4 CONTRACT TIMES, DATES FOR SUBSTANTIAL COMPLETION, AND LIQUIDATED DAMAGES**

4.1 Contract Times

Contractor hereby agrees to commence the work on the Project on or before a date to be specified in a written Notice to Proceed (NTP) from the City, incorporated by reference as set forth herein, and to complete fully the Project within **45 CALENDAR** days or as determined in writing by a mutually agreeable schedule by City Engineer.

#### 4.2 Liquidated Damages

A. Contractor and City recognize that time is of the essence in the performance of the Contract, and that City will incur damages if Contractor does not complete the Work according to the requirements of Paragraph 4.01. Because such damages for delay would be difficult and costly to determine, City and Contractor agree that as liquidated damages for delay (but not as a penalty) Contractor shall pay City **\$250.00** for each day that expires after the Contract Time for substantial completion.

#### 4.3 Delays in Contractor's Progress

A. If City, Engineer, or anyone for whom City is responsible, delays, disrupts, or interferes with the performance or progress of the Work, then Contractor shall be entitled to an equitable adjustment in the Contract Times and Contract Price. Contractor's entitlement to an adjustment of the Contract Times is conditioned on such adjustment being essential to Contractor's ability to complete the Work within the Contract Times.

B. Contractor shall not be entitled to an adjustment in Contract Price or Contract Times for delay, disruption, or interference caused by or within the control of Contractor or their subcontractors or suppliers.

C. If Contractor's performance or progress is delayed, disrupted, or interfered with by unanticipated causes not the fault of and beyond the control of City, Contractor, and those for which they are responsible, then Contractor shall be entitled to an equitable adjustment in Contract Times.

D. Contractor shall not be entitled to an adjustment in Contract Price or Contract Times for any delay, disruption, or interference if such delay is concurrent with a delay, disruption, or interference caused by or within the control of Contractor or Contractor's subcontractors or suppliers.

#### 4.4 Progress Schedules

A. Contractor shall develop a progress schedule and submit to the Engineer for review and comment before starting Work on the Site. The Contractor shall modify the schedule in accordance with the comments provided by the Engineer.

B. The Contractor shall update and submit the progress schedule to the Engineer each month. The City may withhold payment if the Contractor fails to submit the schedule.

## ARTICLE 5 CONTRACT PRICE

### 5.1 Payment

A. Contractor hereby agrees to commence and complete the Work for the sum of \_\_\_\_\_ Dollars (\$\_\_\_\_\_ ) for all services associated with the Work as shown on the Plans under the terms stated in the Contract Documents (Project Manual). All invoices submitted to City by Contractor shall list in detail the services provided.

B. Further, in accordance with the Contract Documents, Contractor agrees, at its own proper cost and expense, to furnish all the materials, supplies, machinery, equipment, tools, superintendence, labor, insurance, and other accessories and services necessary to complete the Project in accordance with the Bid Documents and General Requirements and prices stated in these specifications, which include any maps, plats, blue prints, and other drawings and printed or written explanatory matter thereof, all of which are made a part hereof and collectively constitute the Contract.

### 5.2 Payment Procedure

The basis for progress payments will be incorporated into a form of Application for Payment acceptable to Engineer. ENGINEER will process Applications for Payment. Progress payments for Unit Price Work will be paid for monthly for each unit of Work completed during that pay period.

Payment will be made in an amount equal to the total of all extended prices for actual Work completed. The extended price is determined by multiplying the unit price times the actual quantity of that Work item completed. The Engineer will determine actual quantities installed.

The City agrees to pay the Contractor in current funds for the Work performed under the Contract, subject to additions and deductions, within thirty (30) days of receipt of an Application for Payment approved by Engineer.

## ARTICLE 6 INSURANCE AND BOND

### 6.1 Insurance

A. Before starting Work, Contractor shall, at Contractor's sole cost and expense, procure and maintain for the duration of this Contract proper and complete liability insurance in amounts not less than the following:

General Liability	\$1,000,000
Workers' Compensation	Statutory
Employer's Liability	
Bodily Injury, each Accident	\$1,000,000

Bodily Injury by Disease, each Employee \$1,000,000

Bodily Injury/Disease Aggregate \$1,000,000

.Commercial General Liability

General Aggregate \$ 2,000,000

Products - Completed Operations Aggregate \$ 1,000,000

Personal and Advertising Injury \$ 1,000,000

Each Occurrence (Bodily Injury and Property  
 Damage) \$ 1,000,000

Automobile Liability herein:

Bodily Injury:

Each Person \$ 1,000,000

Each Accident \$ 1,000,000

Property Damage:

Each Accident \$ 1,000,000

Excess or Umbrella Liability:

Per Occurrence \$ 1,000,000

General Aggregate \$ 2,000,000

Contractor's Pollution Liability:

Each Occurrence \$ 1,000,000

General Aggregate \$ 2,000,000

B. All insurance policies required to be purchased and maintained will contain a provision or endorsement that the coverage afforded will not be canceled or materially changed or renewal refused until at least 10 days prior written notice has been given to the insured and additional insured.

C. Automobile liability insurance provided by Contractor shall provide coverage against claims for damages because of bodily injury or death of any person or property damage arising out of the , maintenance, or use of any motor vehicle. The automobile liability policy shall be written on an occurrence basis.

D. Contractor's commercial general liability policy shall be written on the most recent ISO commercial general liability occurrence form and include the following coverages and endorsements:

- .1 Products and completed operations coverage maintained for three years after final payment;
- .2 Blanket contractual liability coverage to the extent permitted by law;
- .3 Broad form property damage coverage; and
- .4 Severability of interest; underground, explosion, and collapse coverage; personal injury coverage.

E. The Contractor's commercial general liability and automobile liability, umbrella or excess, and pollution liability policies shall include and list City, Engineer, and the respective officers, directors, members, partners, employees, agents, consultants, and subcontractors of each as additional insureds; and the insurance afforded to these additional insureds shall provide primary coverage for all claims covered thereby (including as applicable those arising from both ongoing and completed operations) on a non-contributory basis.

- .1 Additional insured endorsements will include both ongoing operations and products and completed operations coverage through ISO Endorsements CG 20 10 10 01 and CG 20 37 10 01 (together). If Contractor demonstrates to City that the specified ISO endorsements are not commercially available, then Contractor may satisfy this requirement by providing equivalent endorsements.
- .2 Contractor shall provide ISO Endorsement CG 20 32 07 04, "Additional Insured – Engineers, Architects or Surveyors Not Engaged by the Named Insured" or its equivalent for design professional additional insureds.

F. Umbrella or excess liability insurance shall be written over the underlying employer's liability, commercial general liability, and automobile liability insurance. Subject to industry standard exclusions, the coverage afforded shall be procured on a "follow the form" basis as to each of the underlying policies. Contractor may demonstrate to City that Contractor has met the combined limits of insurance (underlying policy plus applicable umbrella) specified for employer's liability, commercial general liability, and automobile liability through the primary policies alone, or through combinations of the primary insurance policies and an umbrella or

excess liability policy.

G. The Contractor shall provide property insurance covering physical loss or damage during construction to structures, materials, fixtures, and equipment, including those materials, fixtures, or equipment in storage or transit.

H. If Contractor has failed to obtain and maintain required insurance, City may exclude the Contractor from the Site, impose an appropriate set-off against payment, and exercise City's termination rights under Article 9.

6.2 Contractor shall provide a Performance and Payment Bond equaling the total amount of the bid, (pursuant to Ark. Code Ann. §§ 18-44-503 and 22-9-401. Additionally, if applicable, the Contractor shall provide a Maintenance Bond, equaling 50% of the Street Improvements within the Right-of-Way (ROW) for a period of two (2) years.

## **ARTICLE 7 CONTRACTOR'S RESPONSIBILITIES**

### **7.1 Supervision and Superintendence**

A. Contractor shall supervise and direct the Work competently and efficiently, devoting such attention thereto and applying such skills and expertise as may be necessary to perform the Work in accordance with the Contract Documents. Contractor shall be solely responsible for the means, methods, techniques, sequences, safety, and procedures of construction.

B. Contractor shall assign a competent resident superintendent who is to be present at all times during the execution of the Work. This resident superintendent shall not be replaced without written notice to and approval by the City and Engineer except under extraordinary circumstances

C. Contractor at all times shall maintain good discipline and order at the Site.

### **7.2 Other Work at the Site**

A. In addition to and apart from the Work of the Contractor, other work may occur at or adjacent to the Site. Contractor shall take reasonable and customary measures to avoid damaging, delaying, disrupting, or interfering with the work of City, any other contractor, or any utility City performing other work at or adjacent to the Site.

### **7.3 Services, Materials, and Equipment**

A. Unless otherwise specified in the Contract Documents, Contractor shall provide and assume full responsibility for all services, materials, equipment, labor, transportation, construction equipment and machinery, tools, appliances, fuel, power, light, heat, telephone, water, sanitary facilities, temporary facilities, and all other facilities and incidentals necessary for the performance, testing, start up, and completion of the Work, whether

REMOUNT & BATESVILLE PIKE GUARD RAIL

NLR BID NUMBER: 21-3723

BID DATE: AUGUST 2021

or not such items are specifically called for in the Contract Documents.

B. All materials and equipment incorporated into the Work shall be new, of good quality and shall be stored, applied, installed, connected, erected, protected, used, cleaned, and conditioned in accordance with instructions of the applicable supplier, except as otherwise may be provided in the Contract Documents.

#### 7.4 Subcontractors and Suppliers

A. Contractor may retain subcontractors and suppliers for the performance of parts of the Work. Such subcontractors and suppliers must be acceptable to City.

#### 7.5 Quality Management

A. Contractor is fully responsible for the managing quality to ensure Work is completed in accordance with the Contract Documents.

#### 7.6 Licenses, Fees and Permits

A. Contractor shall pay all license fees and royalties and assume all costs incident to performing the Work or the incorporation in the Work of any invention, design, process, product, or device, which is the subject of patent rights or copyrights held by others.

B. Contractor shall obtain and pay for all construction permits and licenses unless otherwise provided in the Contract Documents.

#### 7.7 Laws and Regulations; Taxes

A. Contractor shall give all notices required by and shall comply with all local, state, and federal Laws and Regulations applicable to the performance of the Work. Except where otherwise expressly required by applicable Laws and Regulations, neither City nor Engineer shall be responsible for monitoring Contractor's compliance with any Laws or Regulations.

B. Contractor shall bear all resulting costs and losses, and shall indemnify and hold harmless City and Engineer, and the officers, directors, members, partners, employees, agents, consultants, and subcontractors of each and any of them from and against all claims, costs, losses, and damages if Contractor performs any Work or takes any other action knowing or having reason to know that it is contrary to Laws or Regulations.

C. Contractor shall pay all applicable sales, consumer, use, and other similar taxes Contractor is required to pay in accordance with Laws and Regulations.



## 7.8 Record Documents

A. Contractor shall maintain one printed record copy of all Drawings, Specifications, Addenda, Change Orders, Work Change Directives, Field Orders, written interpretations and clarifications, and approved shop drawings in a safe place at the Site. Contractor shall annotate them to show changes made during construction. Contractor shall deliver these record documents to Engineer upon completion of the Work.

## 7.9 Safety and Protection

A. Contractor shall be solely responsible for initiating, maintaining, and supervising all safety precautions and programs in connection with the Work.

B. Contractor shall take all necessary precautions for the safety of, and shall provide the necessary protection to prevent damage, injury, or loss to:

.1 All persons on the Site or who may be affected by the Work;

.2 All the Work and materials and equipment to be incorporated therein, whether in storage on or off the Site; and

.3 Other property at the Site or adjacent thereto, including trees, shrubs, lawns, walks, pavements, roadways, structures, other work in progress, utilities, and underground facilities not designated for removal, relocation, or replacement in the course of construction.

C. All damage, injury, or loss to any property caused, directly or indirectly, in whole or in part, by Contractor, or anyone for whose acts the Contractor may be liable, shall be remedied by Contractor at its expense (except damage or loss attributable to the fault of Contract Documents or to the acts or omissions of City or Engineer and not attributable, directly or indirectly, in whole or in part, to the fault or negligence of Contractor).

D. Contractor shall be responsible for coordinating any exchange of material safety data sheets or other hazard communication information required to be made available to or exchanged between or among employers at the Site in accordance with Laws or Regulations.

E. In emergencies affecting the safety or protection of persons or the Work or property at the Site or adjacent thereto, Contractor shall act to prevent threatened damage, injury, or loss. Contractor shall give Engineer prompt written notice if Contractor believes that any significant changes in the Work or variations from the Contract Documents have been caused thereby, or are required as a result thereof. If Engineer determines that a change in the Contract Documents is required because of the action taken by Contractor in response to such an emergency, a Work Change Directive or Change Order will be issued.

## 7.10 Shop Drawings, Samples, and Other Submittals

A. Contractor shall review and coordinate the shop drawing and samples with the requirements of the Work and the Contract Documents and shall verify all related field measurements, quantities, dimensions, specified performance and design criteria, installation requirements, materials, catalog numbers, and similar information.

B. Each submittal shall bear a stamp or specific written certification that Contractor has satisfied Contractor's obligations under the Contract Documents with respect to Contractor's review of that submittal, and that Contractor approves the submittal.

C. With each submittal, Contractor shall give Engineer specific written notice, in a communication separate from the submittal, of any variations that the shop drawing or sample may have from the requirements of the Contract Documents.

D. Engineer will provide timely review of shop drawings and samples.

E. Engineer's review and approval will not extend to means, methods, techniques, sequences, or procedures of construction or to safety precautions or programs.

F. Engineer's review and approval of a separate item does not indicate approval of the assembly in which the item functions.

G. Contractor shall make corrections required by Engineer and shall return the required number of corrected copies of shop drawings and submit, as required, new samples for review and approval. Contractor shall direct specific attention in writing to revisions other than the corrections called for by Engineer on previous submittals.

H. Shop drawings are not Contract Documents.

## 7.11 Representations, Warranties and Guarantees

A. The Contractor warrants that:

.1 Contractor warrants and guarantees to City that all Work will be in accordance with the Contract Documents and will not be defective. Engineer and its officers, directors, members, partners, employees, agents, consultants, and subcontractors shall be entitled to rely on Contractor's warranty and guarantee.

.2 Contractor has full power and authority to enter into this Contract and to carry out the Project contemplated by this Contract.

.3 The Contractor warrants that Contractor will comply with all laws applicable to the performance of the Project under this Contract.

.4 The Contractor warrants that Contractor's execution, delivery, and performance of this Contract will not constitute: (i) a violation of any judgment, order, or decree binding on Contractor; (ii) a breach under any contract by which Contractor is bound; or (iii) an event that would, with notice or lapse of time, or both, constitute such a breach.

.5. The Contractor warrants that the Project will be performed with the degree of skill and care that is required by current, good, sound professional procedures and practices, and in conformance with generally accepted professional procedures and industry standards prevailing at the time the Project is performed, and that all work on the Project meet the specifications set forth herein. Contractor further represents and warrants that Contractor and all personnel used to perform the Project, including permitted subcontractors, possess the knowledge, skill, and experience necessary to perform the Project.

.6 The Contractor warrants that Contractor has, and shall maintain in effect for the duration of this Contract, all licenses, permits qualifications, and approvals of whatsoever nature which are legally required for Contractor to complete the Project. Contractor shall also ensure that all permitted subcontractors are similarly licensed and qualified.

#### 7.12 Correction Period

A. If within one year after the date of substantial completion, any Work is found to be defective, or if the repair of any damages to the Site, adjacent areas that Contractor has arranged to use through construction easements or otherwise, and other adjacent areas used by Contractor as permitted by Laws and Regulations, is found to be defective, then Contractor shall promptly and without cost to City, correct such defective Work.

#### 7.13 Indemnification

A. To the fullest extent permitted by Laws and Regulations, and in addition to any other obligations of Contractor under the Contract or otherwise, Contractor shall indemnify and hold harmless City and Engineer, and the officers, directors, members, partners, employees, agents, consultants and subcontractors of each and any of them from and against all claims, costs, losses, and damages (including but not limited to all fees and charges of engineers, architects, attorneys, and other professionals and all court or arbitration or other dispute resolution costs) arising out of or relating to the performance of the Work, provided that any such claim, cost, loss, or damage is attributable to bodily injury, sickness, disease, or death, or to injury to or destruction of tangible property (other than the Work itself), including the loss of use resulting therefrom but only to the extent caused by any negligent act or omission of Contractor, any subcontractor, any technical , or any individual or entity directly or indirectly employed by any of them to perform any of the Work or anyone for whose acts they may be liable.

## **ARTICLE 8 CITY'S RESPONSIBILITIES**

### **8.1 City's Responsibilities**

A. Except as otherwise provided in the Contract Documents, City shall issue all communications to Contractor through Engineer.

B. City shall make payments to Contractor as provided in this Contract.

C. City shall provide Site and easements required to construct the Project.

D. If City intends to contract with others for the performance of other work at or adjacent to the Site, unless stated elsewhere in the Contract Documents, City shall have sole authority and responsibility for such coordination.

E. The City shall be responsible for performing inspections and tests required by applicable codes.

F. The City shall not supervise, direct, or have control or authority over, nor be responsible for, Contractor's means, methods, techniques, sequences, or procedures of construction, or the safety precautions and programs, or for any failure of Contractor to comply with Laws and Regulations applicable to the performance of the Work. City will not be responsible for Contractor's failure to perform the Work in accordance with the Contract Documents.

G. While at the Site, City's employees and representatives shall comply with the specific applicable requirements of Contractor's safety programs of which City has been informed.

H. City shall furnish copies of any applicable City safety programs to Contractor.

## **ARTICLE 9 ENGINEER'S STATUS DURING CONSTRUCTION**

### **9.2 Engineer's Status**

A. Engineer will be City's representative during construction. The duties and responsibilities and the limitations of authority of Engineer as City's representative during construction are set forth in this Contract.

B. Neither Engineer's authority or responsibility under this Article 9 or under any other provision of the Contract, nor any decision made by Engineer in good faith either to exercise or not exercise such authority or responsibility or the undertaking, exercise, or performance of any authority or responsibility by Engineer, shall create, impose, or give rise to any duty in contract, tort, or otherwise owed by Engineer to Contractor, any subcontractor, any supplier, any other individual or entity, or to any surety for or employee or agent of any of them.

C. Engineer will make visits to the Site at intervals appropriate to the various stages of construction. Engineer will not be required to make exhaustive or continuous inspections on the Site to check the quality or quantity of the Work.

D. Engineer has the authority to reject Work if Contractor fails to perform Work in  
REMOUNT & BATESVILLE PIKE GUARD RAIL  
NLR BID NUMBER: 21-3723  
BID DATE: AUGUST 2021

accordance with the Contract Documents.

E. Engineer will render decisions regarding the requirements of the Contract Documents, and judge the acceptability of the Work.

F. Engineer will not supervise, direct, control, or have authority over or be responsible for Contractor's means, methods, techniques, sequences, or procedures of construction, or the safety precautions and programs, or for any failure of Contractor to comply with Laws and Regulations applicable to the performance of the Work. Engineer will not be responsible for Contractor's failure to perform the Work in accordance with the Contract Documents.

## **ARTICLE 10 CHANGES IN THE WORK**

### *10.1 Authority to Change the Work*

A. Without invalidating the Contract and without notice to any surety, City may, at any time or from time to time, order additions, deletions, or revisions in the Work, in writing.

### *10.2 Change Orders*

A. City and Contractor shall execute appropriate Change Orders covering:

.1 Changes in the Contract Price or Contract Times which are agreed to by the parties, including any undisputed sum or amount of time for Work actually performed in accordance with a Work Change Directive; provided, however, that any increase in Contract Price has been duly appropriated by the City Council and authorized;

2. Changes in the Work which are: (a) ordered by City or (b) agreed to by the parties or (c) resulting from the Engineer's decision, subject to the need for Engineer's recommendation if the change in the Work involves the design (as set forth in the Drawings, Specifications, or otherwise), or other engineering or technical matters; and

3. Changes in the Contract Price or Contract Times or other changes which embody the substance of any final binding results under Article 12.

B. If the provisions of any bond require notice to be given to a surety of any change affecting the general scope of the Work or the provisions of the Contract Documents (including, but not limited to, Contract Price or Contract Times), the giving of any such notice will be Contractor's responsibility. The amount of each applicable bond will be adjusted to reflect the effect of any such change.

## **ARTICLE 11 DIFFERING SUBSURFACE OR PHYSICAL CONDITIONS**

### 11.1 Differing Conditions Process

A. If Contractor believes that any subsurface or physical condition including but not limited to utilities or other underground facilities that are uncovered or revealed at the Site either differs materially from that shown or indicated in the Contract Documents or is of an unusual nature, and differs materially from conditions ordinarily encountered and generally recognized as inherent in Work of the character provided for in the Contract Documents then Contractor shall, promptly after becoming aware thereof and before further disturbing the subsurface or physical conditions or performing any Work in connection therewith (except in an emergency), notify City and Engineer in writing about such condition. Contractor shall not further disturb such condition or perform any Work in connection therewith (except with respect to an emergency) until receipt of a written statement permitting Contractor to do so.

B. After receipt of written notice, Engineer will promptly:

1. Review the subsurface or physical condition in question;
2. Determine necessity for City obtaining additional exploration or tests with respect to the condition;
3. Determine whether the condition falls within the differing site condition as stated herein;
4. Obtain any pertinent cost or schedule information from Contractor;
5. Prepare recommendations to City regarding the Contractor's resumption of Work in connection with the subsurface or physical condition in question and the need for any change in the Drawings or Specifications; and
6. Advise City in writing of Engineer's findings, conclusions, and recommendations.

C. After receipt of Engineer's written findings, conclusions, and recommendations, City shall issue a written statement to Contractor regarding the subsurface or physical condition in question, addressing the resumption of Work in connection with such condition, indicating whether any change in the Drawings or Specifications will be made, and adopting or rejecting Engineer's written findings, conclusions, and recommendations, in whole or in part.

## **ARTICLE 12 CLAIMS AND DISPUTE RESOLUTION**

### 12.1 Claims Process

A. The party submitting a claim shall deliver it directly to the other party to the Contract and the Engineer promptly (but in no event later than 10 days) after the start of the event giving rise thereto.

B. The party receiving a claim shall review it thoroughly, giving full consideration to its merits. The two parties shall seek to resolve the claim through the exchange of information and direct negotiations. All actions taken on a claim shall be stated in writing and submitted to the other party.

C. If efforts to resolve a claim are not successful, the party receiving the claim may deny it by giving written notice of denial to the other party. If the receiving party does not take action on the claim within 45 days, the claim is deemed denied.

D. If the dispute is not resolved to the satisfaction of the parties, City or Contractor shall give written notice to the other party of the intent to submit the dispute to a court of competent jurisdiction unless the City and Contractor both agree to submit the dispute to mediation, prior to any litigation. In that case, an alternative dispute resolution firm located in Pulaski County, Arkansas, agreed upon by the parties, shall conduct mediation. The parties shall share the costs of mediation equally.

## **ARTICLE 13 - TESTS AND INSPECTIONS; CORRECTION OF DEFECTIVE WORK**

### 13.1 Tests and Inspections

A. City and Engineer will have access to the Site and the Work at reasonable times for their observation, inspection, and testing. Contractor shall provide them proper and safe conditions for such access.

B. Contractor shall give Engineer timely notice of readiness of the Work for all required inspections and tests, and shall cooperate with inspection and testing personnel to facilitate required inspections and tests.

C. If any Work that is to be inspected, tested, or approved is covered by Contractor without written concurrence of Engineer, Contractor shall, if requested by Engineer, uncover such Work for observation. Such uncovering shall be at Contractor's expense.

### 13.2 Defective Work

A. Contractor shall ensure that the Work is not defective.

B. Engineer has the authority to determine whether Work is defective, and to reject defective Work.

C. Prompt notice of all defective Work of which City or Engineer has actual knowledge will be given to Contractor.

D. The Contractor shall promptly correct all such defective Work.

E. When correcting defective Work, Contractor shall take no action that would void or otherwise impair City's special warranty and guarantee, if any, on said Work.

F. If the Work is defective or Contractor fails to supply sufficient skilled workers or suitable materials or equipment, or fails to perform the Work in such a way that the completed Work will conform to the Contract Documents, then City may order Contractor to stop the Work, or any portion thereof, until the cause for such order has been eliminated.

## **ARTICLE 14 - PAYMENTS TO CONTRACTOR**

### **14.1 Progress Payments**

A. The Contractor shall prepare a schedule of values that will serve as the basis for progress payments. The schedule of values will be in a form of application for payment acceptable to Engineer. The unit price breakdown submitted with the bid will be used for unit price work, as described in Section 5.02. Break lump sum items into units that will allow for measurement of Work in progress.

### **14.2 Applications for Payments:**

A. Contractor shall submit an application for payment in a form acceptable to the Engineer, no more frequently than monthly, to Engineer. Applications for payment will be prepared and signed by Contractor. Contractor shall provide supporting documentation required by the Contract Documents. Payment will be paid for Work completed as of the date of the application for payment.

B. Beginning with the second application for payment, each application shall include an affidavit of Contractor stating that all previous progress payments received on account of the Work have been applied on account to discharge Contractor's legitimate obligations associated with prior applications for payment.

### **14.3 Retainage**

A. The City shall retain 5% of each progress payment until the Work is substantially complete.

### **14.4 Review of Applications**

A. Within 10 days after receipt of each Application for Payment, the Engineer will either indicate in writing a recommendation for payment and present the Application for Payment to City or return the Application for Payment to Contractor indicating in writing Engineer's reasons for refusing to recommend payment. The Contractor will make the necessary corrections and resubmit the application for payment.



B. Engineer will recommend reductions in payment (set-offs) which, in the opinion of the Engineer, are necessary to protect City from loss because the Work is defective and requires correction or replacement.

C. The City is entitled to impose set-offs against payment based on any claims that have been made against City on account of Contractor's conduct in the performance of the Work, incurred costs, losses, or damages on account of Contractor's conduct in the performance of the Work, or liquidated damages that have accrued as a result of Contractor's failure to complete the Work.

#### 14.5 Contractor's Warranty of Title

A. Contractor warrants and guarantees that title to all Work, materials, and equipment furnished under the Contract will pass to City free and clear of (1) all liens and other title defects, and (2) all patent, licensing, copyright, or royalty obligations, no later than seven days after the time of payment by City.

#### 14.6 Substantial Completion

A. The Contractor shall notify City and Engineer in writing that the Work is substantially complete and request the Engineer issue a certificate of substantial completion when Contractor considers the Work ready for its intended use. Contractor at the same time shall submit to City and Engineer an initial draft of punch list items to be completed or corrected before final payment.

B. Engineer will make an inspection of the Work with the City and Contractor to determine the status of completion. If Engineer does not consider the Work substantially complete, Engineer will notify Contractor and City in writing giving the reasons therefor.

C. If Engineer considers the Work substantially complete or upon resolution of all reasons for non-issuance of a certificate identified in 14.06.B, Engineer will deliver to City a certificate of substantial completion which shall fix the date of substantial completion and include a punch list of items to be completed or corrected before final payment.

#### 14.7 Final Inspection

A. Upon written notice from Contractor that the entire Work is complete, Engineer will promptly make a final inspection with City and Contractor and will notify Contractor in writing of all particulars in which this inspection reveals that the Work, or agreed portion thereof, is incomplete or defective. Contractor shall immediately take such measures as are necessary to complete such Work or remedy such deficiencies.

#### 14.8 Final Payment

A. Contractor may make application for final payment after Contractor has satisfactorily completed all Work defined in the Contract, including providing all maintenance and operating instructions, schedules, guarantees, bonds, certificates or other evidence of insurance, certificates of inspection, annotated record documents and other documents.

B. The final application for payment shall be accompanied (except as previously delivered) by:

- .1 All documentation called for in the Contract Documents;
- .2 Consent of the surety to final payment;
- .3 Satisfactory evidence that all title issues have been resolved such that title to all Work, materials, and equipment has passed to City free and clear of any liens or other title defects, or will so pass upon final payment;
- .4 A list of all disputes that Contractor believes are unsettled; and
- .5 Complete and legally effective releases or waivers (satisfactory to City) of all lien rights arising out of the Work, and of liens filed in connection with the Work

C. The Work is complete (subject to surviving obligations) when it is ready for final payment as established by the Engineer's written recommendation of final payment.

#### 14.9 Waiver of Claims

A. The making of final payment will not constitute a waiver by City of claims or rights against Contractor.

B. The acceptance of final payment by Contractor will constitute a waiver by Contractor of all claims and rights against City other than those pending matters that have been duly submitted.

### **ARTICLE 15 SUSPENSION OF WORK AND TERMINATION**

#### 15.1 City May Suspend Work

A. At any time and without cause, City may suspend the Work or any portion thereof for a period of not more than 60 consecutive days by written notice to Contractor and Engineer. Such notice will fix the date on which Work will be resumed. Contractor shall resume the Work on the date so fixed. Contractor shall be entitled to an adjustment in the Contract Price or an extension of the Contract Times, or both, upon submitting documentary evidence of loss directly attributable to any such suspension, to the satisfaction of City.

## 15.2 City May Terminate for Cause

A. Contractor's failure to perform the Work in accordance with the Contract Documents or other failure to comply with a material term of the Contract Documents will constitute a default by Contractor and justify termination for cause.

B. If Contractor defaults in its obligations, then after giving Contractor and any surety ten days written notice that City is considering a declaration that Contractor is in default and termination of the Contract, City may proceed to:

- .1 Declare Contractor to be in default, and give Contractor and any surety notice that the Contract is terminated; and
- .2 Enforce the rights available to City under any applicable performance bond.

C. City may not proceed with termination of the Contract under Paragraph 9.02.B if Contractor within seven days of receipt of notice of intent to terminate begins to correct its failure to perform and proceeds diligently to cure such failure.

D. Subject to the terms and operation of any applicable performance bond, if City has terminated the Contract for cause, City may exclude Contractor from the Site, take possession of the Work, incorporate in the Work all materials and equipment stored at the Site or for which City has paid Contractor but which are stored elsewhere, and complete the Work as City may deem expedient.

E. In the case of a termination for cause, if the cost to complete the Work, including related claims, costs, losses, and damages, exceeds the unpaid contract balance, Contractor shall pay the difference to City.

## 15.3 City May Terminate for Convenience

A. Notwithstanding any other provision of this Contract, upon seven days written notice to Contractor, the City may, without cause and without prejudice to any other right or remedy of City, terminate the Contract. This right includes, but is not limited to, termination due to non-appropriation of funds in sufficient amounts to discharge such obligation; such failure (i) shall act to terminate this Contract at such time as the then-existing and available appropriations are depleted, and (ii) neither such failure nor termination shall constitute a default or breach of this Contract, including any sub-agreement, attachment, schedule, or exhibit thereto, by the City. As used herein, the term "appropriation" shall mean and include the due adoption of an appropriation ordinance and budget and the approval of availability of sufficient funds for the performance of fiscal obligations arising under this Contract. In such case, without duplication of any items, Contractor shall be paid for::

- .1 Completed and acceptable Work executed in accordance with the Contract Documents prior to the effective date of termination;

.2 Expenses sustained prior to the effective date of termination in performing services and furnishing labor, materials, or equipment as required by the Contract Documents in connection with uncompleted Work; and

.3 Other reasonable, documented expenses directly attributable to termination, including costs incurred to prepare a termination for convenience cost proposal.

#### 15.4 Contractor May Stop Work or Terminate

A. If, through no act or fault of Contractor, (1) the Work is suspended for more than 90 consecutive days by City or under an order of court or other public authority, or (2) City fails for 30 days to pay Contractor any sum finally determined to be due, then Contractor may, upon seven days written notice to City, and provided City does not remedy such suspension or failure within that time, either stop the Work until payment is received, or terminate the Contract and recover payment from the City.

### **ARTICLE 16 CONTRACTOR'S REPRESENTATIONS**

#### 16.1 Contractor's Representations

A. In order to induce City to enter into this Contract Contractor makes the following representations:

.1 Contractor has examined and carefully studied the Contract Documents and the other related data identified in the Bidding Documents.

.2 Contractor has visited the Site and become familiar with and is satisfied as to the general, local, and Site conditions that may affect cost, progress, and performance of the Work.

.3 Contractor is familiar with and is satisfied as to all federal, state and local laws, regulations, and ordinances that may affect cost, progress, and performance of the Work. All Work shall be completed in accordance with all applicable federal, state, and local laws, regulations, and ordinances.

.4 Contractor has carefully studied all: (1) drawings of physical conditions in or relating to existing surface or subsurface structures at or contiguous to the Site (except Underground Facilities), if applicable, which have been provided as described in paragraph 5.03 of the EJCDC Standard General Conditions of the Construction Contract, as modified and (2) reports and drawings of a Hazardous Environmental Condition, if any, at the Site which has been identified in the General Conditions, if applicable, as provided in paragraph 5.06 of the EJCDC Standard General Conditions of the Construction Contract, as modified.

.5 Contractor has obtained and carefully studied (or assumes responsibility for having done so) all additional or supplementary examinations, investigations,

explorations, tests, studies, and data concerning conditions (surface, subsurface, and Underground Facilities) at or contiguous to the Site which may affect cost, progress, or performance of the Work or which relate to any aspect of the means methods, techniques, sequences, and procedures of construction, if any, expressly required by the Contract Documents to be employed by Contractor, and safety precautions and programs incident thereto.

.6 Contractor does not consider that any further examinations, investigations, explorations, tests, studies, or data are necessary for the performance of the Work at the Contract Price, within the Contract Times, and in accordance with the other terms and conditions of the Contract Documents.

.7 Contractor is aware of the general nature of work to be performed by City and others at the Site that relates to the Work as indicated in the Contract Documents.

.8 Contractor has correlated the information known to Contractor, information and observations obtained from visits to the Site, reports and drawings identified in the Contract Documents, and all additional examinations, investigations, explorations, tests, studies, and data with the Contract Documents.

.9 Contractor has given Engineer written notice of all conflicts, errors, ambiguities, or discrepancies that Contractor has discovered in the Contract Documents, and the written resolution thereof by Engineer is acceptable to Contractor.

.10 The Contract Documents are generally sufficient to indicate and convey understanding of all terms and conditions for performance and furnishing of the Work.

## **ARTICLE 17 DEFINITIONS**

17.1 Addenda—Written or graphic instruments issued prior to the opening of Bids which clarify, correct, or change the Bidding Requirements or the proposed Contract Documents.

17.2 Agreement—The written instrument, executed by Owner and Contractor, that sets forth the Contract Price and Contract Times, identifies the parties and the Engineer, and designates the specific items that are Contract Documents.

17.3 Application for Payment—The document prepared by Contractor, in a form acceptable to Engineer, to request progress or final payments, and which is to be accompanied by such supporting documentation as is required by the Contract Document

17.4 Change Order—A document which is signed by Contractor and Owner and authorizes an addition, deletion, or revision in the Work or an adjustment in the Contract Price or the Contract Times, or other revision to the Contract, issued on or after the Effective Date of the Contract.

17.5 Claim – A dispute between Contractor and City arising from the Work seeking resolution

REMOUNT & BATESVILLE PIKE GUARD RAIL

NLR BID NUMBER: 21-3723

BID DATE: AUGUST 2021

of a contractual issue.

17.6 Contract—The entire and integrated written contract between Owner and Contractor concerning the Work.

17.7 Contract Documents—Those items so designated in the Agreement, and which together comprise the Contract.

17.8 Contract Price—The money that Owner has agreed to pay Contractor for completion of the Work in accordance with the Contract Documents.

17.9 Contract Times—The number of days or the dates by which Contractor shall: (a) achieve Milestones, if any; (b) achieve Substantial Completion; and (c) complete the Work.

17.10 Contractor—The individual or entity with which Owner has contracted for performance of the Work.

17.11 Drawings—The part of the Contract that graphically shows the scope, extent, and character of the Work to be performed by Contractor.

17.12 Effective Date of the Contract—The date, indicated in the Agreement, on which the Contract becomes effective.

17.13 Electronic Means—Electronic mail (email), upload/download from a secure Project website, or other communications methods that allow: (a) the transmission or communication of Electronic Documents; (b) the documentation of transmissions, including sending and receipt; (c) printing of the transmitted Electronic Document by the recipient; (d) the storage and archiving of the Electronic Document by sender and recipient; and (e) the use by recipient of the Electronic Document for purposes permitted by this Contract. Electronic Means does not include the use of text messaging, or of Facebook, Twitter, Instagram, or similar social media services for transmission of Electronic Documents.

17.14 Engineer—The individual or entity named as such in the Agreement.

17.15 Field Order—A written order issued by Engineer which requires minor changes in the Work but does not change the Contract Price or the Contract Times.

17.16 Hazardous Environmental Condition—The presence at the Site of Constituents of Concern in such quantities or circumstances that may present a danger to persons or property exposed thereto.

a. The presence at the Site of materials that are necessary for the execution of the Work, or that are to be incorporated into the Work, and that are controlled and contained pursuant to industry

practices, Laws and Regulations, and the requirements of the Contract, is not a Hazardous Environmental Condition.

b. The presence of Constituents of Concern that are to be removed or remediated as part of the Work is not a Hazardous Environmental Condition.

c. The presence of Constituents of Concern as part of the routine, anticipated, and obvious working conditions at the Site, is not a Hazardous Environmental Condition.

17.17 Laws and Regulations; Laws or Regulations—Any and all applicable laws, statutes, rules, regulations, ordinances, codes, and binding decrees, resolutions, and orders of any and all governmental bodies, agencies, authorities, and courts having jurisdiction.

17.18 Liens—Charges, security interests, or encumbrances upon Contract-related funds, real property, or personal property.

17.19 Notice to Proceed—A written notice by Owner to Contractor fixing the date on which the Contract Times will commence to run and on which Contractor shall start to perform the Work.

17.20 Owner—The individual or entity with which Contractor has contracted regarding the Work, and which has agreed to pay Contractor for the performance of the Work, pursuant to the terms of the Contract.

17.21 Progress Schedule—A schedule, prepared and maintained by Contractor, describing the sequence and duration of the activities comprising Contractor's plan to accomplish the Work within the Contract Times.

17.22 Project—The total undertaking to be accomplished for Owner by engineers, contractors, and others, including planning, study, design, construction, testing, commissioning, and start-up, and of which the Work to be performed under the Contract Documents is a part.

17.23 Samples—Physical examples of materials, equipment, or workmanship that are representative of some portion of the Work and that establish the standards by which such portion of the Work will be judged.

17.24 Schedule of Values—A schedule, prepared and maintained by Contractor, allocating portions of the Contract Price to various portions of the Work and used as the basis for reviewing Contractor's Applications for Payment.

17.25 Shop Drawings—All drawings, diagrams, illustrations, schedules, and other data or information that are specifically prepared or assembled by or for Contractor and submitted by Contractor to illustrate some portion of the Work. Shop Drawings, whether approved or not, are not Drawings and are not Contract Documents.

17.26 Site—Lands or areas indicated in the Contract Documents as being furnished by Owner upon which the Work is to be performed, including rights-of-way and easements, and such other lands or areas furnished by Owner which are designated for the use of Contractor.

17.27 Specifications—The part of the Contract that consists of written requirements for materials, equipment, systems, standards, and workmanship as applied to the Work, and certain administrative requirements and procedural matters applicable to the Work.

17.28 Subcontractor—An individual or entity having a direct contract with Contractor or with any other Subcontractor for the performance of a part of the Work.

17.29 Submittal—A written or graphic document, prepared by or for Contractor, which the Contract Documents require Contractor to submit to Engineer, or that is indicated as a Submittal in the Schedule of Submittals accepted by Engineer. Submittals may include Shop Drawings and Samples; schedules; product data; Owner-delegated designs; sustainable design information; information on special procedures; testing plans; results of tests and evaluations, source quality-control testing and inspections, and field or Site quality-control testing and inspections; warranties and certifications; Suppliers' instructions and reports; records of delivery of spare parts and tools; operations and maintenance data; Project photographic documentation; record documents; and other such documents required by the Contract Documents. Submittals, whether or not approved or accepted by Engineer, are not Contract Documents. Change Orders, Claims, notices, Applications for Payment, and requests for interpretation or clarification are not Submittals.

17.30 Substantial Completion—The time at which the Work (or a specified part thereof) has progressed to the point where, in the opinion of Engineer, the Work (or a specified part thereof) is sufficiently complete, in accordance with the Contract Documents, so that the Work (or a specified part thereof) can be utilized for the purposes for which it is intended. The terms “substantially complete” and “substantially completed” as applied to all or part of the Work refer to Substantial Completion of such Work.

17.31 Supplier—A manufacturer, fabricator, supplier, distributor, or vendor having a direct contract with Contractor or with any Subcontractor to furnish materials or equipment to be incorporated in the Work by Contractor or a Subcontractor.

17.32 Underground Facilities—All active or not-in-service underground lines, pipelines, conduits, ducts, encasements, cables, wires, manholes, vaults, tanks, tunnels, or other such facilities or systems at the Site, including but not limited to those facilities or systems that produce, transmit, distribute, or convey telephone or other communications, cable television, fiber optic transmissions, power, electricity, light, heat, gases, oil, crude oil products, liquid petroleum products, water, steam, waste, wastewater, storm water, other liquids or chemicals, or



traffic or other control systems. An abandoned facility or system is not an Underground Facility.

17.33 Unit Price Work—Work to be paid for on the basis of unit prices.

17.34 Work—The entire construction or the various separately identifiable parts thereof required to be provided under the Contract Documents. Work includes and is the result of performing or providing all labor, services, and documentation necessary to produce such construction; furnishing, installing, and incorporating all materials and equipment into such construction; and may include related services such as testing, start-up, and commissioning, all as required by the Contract Documents.

17.35 Work Change Directive—A written directive to Contractor issued on or after the Effective Date of the Contract, signed by Owner and recommended by Engineer, ordering an addition, deletion, or revision in the Work.

## **ARTICLE 18 MISCELLANEOUS**

### 18.1 Terms

A. Terms used in this Contract will have the meanings indicated in the standard General Conditions of the Construction Contract, as modified.

### 18.2 Restrictions on Public Improvement Contracts

A. In accordance with the Bid Documents, all bid documents related to public improvements exceeding \$75,000 in value must include a statement that encourages participation of small, minority, and women's business enterprises.

B. Contractor, in accordance with Ark. Code Ann. §§ 18-44-503 and 22-9-401, must furnish a surety bond in an amount equal to the contract price.

C. In accordance with Ark. Code Ann. § 22-9-601, et seq., Contractor is subject to the retainage provisions which allows the City to retain five percent (5%) of payments until final project completion.

D Contractor acknowledges that a public right-of-way is an easement used for ingress and egress to property. The City holds these easements for the benefit of the public at large. As part of any public improvement contract performed in or about public rights-of-way, the City requires and Contractor agrees that such rights-of-way will be repaired, to the extent possible, to the condition prior to the performance of work.

### 18.3 Choice of Law

A. The parties hereto agree that this Contract shall be construed under Arkansas law, excluding its conflict of laws rules. The parties further agree that proper jurisdiction and venue for any cause of action arising from this Contract shall be vested in either the U.S. District Court for

REMOUNT & BATESVILLE PIKE GUARD RAIL

NLR BID NUMBER: 21-3723

BID DATE: AUGUST 2021

the Eastern District of Arkansas or the Circuit Court of Pulaski County, Arkansas.

#### 18.4 Non-Waiver

A. No delay or failure to exercise any right under this Contract shall impair any such right or be construed to be a waiver thereof. No waiver shall be effective unless in writing signed by the party waiving. A waiver of a right on one occasion shall not be deemed to be waiver of such right on any other occasion. A waiver of a right on one occasion shall not be deemed to be a waiver of any other right on that occasion.

#### 18.5 No Assignment.

A. The Project to be performed pursuant to this Contract is personal in nature, and Contractor may not, voluntarily or by operation of law, assign or transfer any of its rights or obligations under this Contract without the prior written consent of the City.

#### 18.6 Merger

A. This Contract constitutes the full understanding of the parties, a complete allocation of risks between them and a complete and exclusive statement of the terms and conditions of their agreement, related to the services provided hereunder. All prior agreements, negotiations, dealings and understandings, whether written or oral, regarding the subject matter hereof, are superseded by and merged into this Contract.

#### 18.7 Modification

A. No conditions, usage of trade, course of dealing or performance, understanding or agreement purporting to modify, vary the terms or conditions of the Contract shall be binding unless hereafter made in writing and signed by the party to be bound, and no modification shall be effected by the acknowledgment or acceptance of any forms containing terms or conditions or variance with or in addition to those set forth in this Contract.

#### 18.8 Severability

A. Any provision or part of the Contract Documents held to be void or unenforceable under any Law or Regulation shall be deemed stricken, and all remaining provisions shall continue to be valid and binding upon City and Contractor, who agree that the Contract Documents shall be reformed to replace such stricken provision or part thereof with a valid and enforceable provision that comes as close as possible to expressing the intention of the stricken provision.

#### 18.9 Cumulative Remedies

A. The duties and obligations imposed by this Contract and the rights and remedies available hereunder to the parties hereto are in addition to, and are not to be construed in any way as a limitation of, any rights and remedies available to any or all of them which are otherwise imposed or available by Laws or Regulations, by special warranty or guarantee, or by other provisions of the Contract. The provisions of this paragraph will be as effective as if repeated specifically in the Contract Documents in connection with each particular

REMOUNT & BATESVILLE PIKE GUARD RAIL

NLR BID NUMBER: 21-3723

BID DATE: AUGUST 2021

duty, obligation, right, and remedy to which they apply.

#### 18.10 Limitation of Damages

A. Neither City, Engineer, nor any of their officers, directors, members, partners, employees, agents, consultants, or subcontractors, shall be liable to Contractor for any claims, costs, losses, or damages sustained by Contractor on or in connection with any other project or anticipated project.

#### 18.11 Survival of Obligations

A. All representations, indemnifications, warranties, and guarantees made in, required by, or given in accordance with the Contract, as well as all continuing obligations indicated in the Contract, will survive final payment, completion, and acceptance of the Work or termination or completion of the Contract or termination of the services of Contractor.

#### 18.12 Contractor's Certifications

A. Contractor certifies that it has not engaged in corrupt, fraudulent, collusive, or coercive practices in competing for or in executing the Contract.

#### 18.13 No Presumption against Drafter

A. Each of the parties hereto has jointly participated in the negotiation and drafting of this Contract. In the event an ambiguity or a question of intent or interpretation arises, this Contract shall be construed as if drafted jointly by each of the parties hereto and no presumptions or burdens of proof shall arise favoring any party by virtue of the authorship of any provisions of this Contract.

#### 18.14 Counterpart Execution

A. This Contract may be executed in two or more counterparts, each of which is deemed as original but all constitute one and the same instrument. An original signature transmitted by facsimile or other electronic means shall be deemed to be original.

18.15 Filing. This document shall be filed in the official records of the City Clerk of the City of North Little Rock, Arkansas. Either party may additionally file this document in any other governmental office deemed appropriate; however, the parties waive all claims and defenses in law or equity based upon such additional filing.

[Signatures on the Next Page]

IN WITNESS WHEREOF, the parties have caused this Contract to be duly executed intending to be bound thereby.

**City of North Little Rock**

**[Contractor]**

By: \_\_\_\_\_

By: \_\_\_\_\_

**Terry Hartwick, Mayor**

**Name and Title**

\_\_\_\_\_  
**Date**

\_\_\_\_\_  
**Date**

**ATTEST:**

\_\_\_\_\_  
**Diane Whitbey, City Clerk**

*Contract reviewed and approved as to form by:*

**Amy Beckman Fields**  
**North Little Rock City Attorney**

BY: \_\_\_\_\_  
**Deputy City Attorney      Date**

**NOTICE TO PROCEED**

**TO:**

**PROJECT: REMOUNT & BATESVILLE PIKE GUARD RAIL**  
**City Project No. 21-24**

You are hereby notified to commence WORK in accordance with the Contract dated \_\_\_\_\_ on or before \_\_\_\_\_, and you are to complete the WORK within \_\_\_\_\_ consecutive calendar days thereafter. The date of completion of all WORK is therefore \_\_\_\_\_, 20\_\_.

Owner

By \_\_\_\_\_

**ACCEPTANCE OF NOTICE**

Receipt of the above NOTICE TO PROCEED is hereby acknowledged by

\_\_\_\_\_ this the \_\_\_\_\_ day of \_\_\_\_\_ 20\_\_.

By \_\_\_\_\_

Title \_\_\_\_\_

## Contractor's Application for Payment No.

	Application Period:	Application Date:
To (Owner):	From (Contractor):	Via (Engineer):
Project:	Contract:	
Owner's Contract No.:	Contractor's Project No.:	Engineer's Project No.:

### Application For Payment Change Order Summary

Approved Change Orders				
Number	Additions	Deductions		
TOTALS				
NET CHANGE BY CHANGE ORDERS				

<b>1. ORIGINAL CONTRACT PRICE</b> .....	\$ _____
<b>2. Net change by Change Orders</b> .....	\$ _____
<b>3. Current Contract Price (Line 1 ± 2)</b> .....	\$ _____
<b>4. TOTAL COMPLETED AND STORED TO DATE</b> (Column F on Progress Estimate).....	\$ _____
<b>5. RETAINAGE:</b>	
a.     X     _____ Work Completed.....	\$ _____
b.     X     _____ Stored Material.....	\$ _____
c. Total Retainage (Line 5a + Line 5b).....	\$ _____
<b>6. AMOUNT ELIGIBLE TO DATE (Line 4 - Line 5c)</b> .....	\$ _____
<b>7. LESS PREVIOUS PAYMENTS (Line 6 from prior Application)</b> .....	\$ _____
<b>8. AMOUNT DUE THIS APPLICATION</b> .....	\$ _____
<b>9. BALANCE TO FINISH, PLUS RETAINAGE</b> (Column G on Progress Estimate + Line 5 above).....	\$ _____

<b>Contractor's Certification</b>	
<p>The undersigned Contractor certifies that to the best of its knowledge: (1) all previous progress payments received from Owner on account of Work done under the Contract have been applied on account to discharge Contractor's legitimate obligations incurred in connection with Work covered by prior Applications for Payment; (2) title of all Work, materials and equipment incorporated in said Work or otherwise listed in or covered by this Application for Payment will pass to Owner at time of payment free and clear of all Liens, security interests and encumbrances (except such as are covered by a Bond acceptable to Owner indemnifying Owner against any such Liens, security interest or encumbrances); and (3) all Work covered by this Application for Payment is in accordance with the Contract Documents and is not defective.</p>	
By:	Date:

Payment of:	\$ _____
	(Line 8 or other - attach explanation of the other amount)
is recommended by:	_____ (Date)
	(Engineer)
Payment of:	\$ _____
	(Line 8 or other - attach explanation of the other amount)
is approved by:	_____ (Date)
	(Owner)
Approved by:	_____ (Date)
	Funding Agency (if applicable)







# Stored Material Summary

# Contractor's Application

For (contract):						Application Number:			
Application Period:						Application Date:			
A	B	C	D		E		F		G
Invoice No.	Shop Drawing Transmittal No.	Materials Description	Stored Previously		Stored this Month		Incorporated in Work		Materials Remaining in Storage (\$) (D + E - F)
			Date (Month/Year)	Amount (\$)	Amount (\$)	Subtotal	Date (Month/Year)	Amount (\$)	
<b>Totals</b>									

# Change Order

No. \_\_\_\_\_

Date of Issuance: \_\_\_\_\_

Effective Date: \_\_\_\_\_

Project:	Owner: City of North Little Rock Arkansas	Owner's Contract No.:
Contract:		Date of Contract:
Contractor:		Engineer's Project No.: Project No.

## The Contract Documents are modified as follows upon execution of this Change Order:

Description:

### Attachments (list documents supporting change):

#### CHANGE IN CONTRACT PRICE:

#### CHANGE IN CONTRACT TIMES:

Original Contract Price:

\$ \_\_\_\_\_

[Increase] [Decrease] from previously approved  
Change Orders No. \_\_\_\_\_ to No. \_\_\_\_\_:

\$ \_\_\_\_\_

Contract Price prior to this Change Order:

\$ \_\_\_\_\_

[Increase] [Decrease] of this Change Order:

\$ \_\_\_\_\_

Contract Price incorporating this Change Order:

\$ \_\_\_\_\_

Original Contract Times:  Working days  Calendar days

Substantial completion (days or date): \_\_\_\_\_

Ready for final payment (days or date): \_\_\_\_\_

[Increase] [Decrease] from previously approved Change Orders  
No. \_\_\_\_\_ to No. \_\_\_\_\_:

Substantial completion (days): \_\_\_\_\_

Ready for final payment (days): \_\_\_\_\_

Contract Times prior to this Change Order:

Substantial completion (days or date): \_\_\_\_\_

Ready for final payment (days or date): \_\_\_\_\_

[Increase] [Decrease] of this Change Order:

Substantial completion (days or date): \_\_\_\_\_

Ready for final payment (days or date): \_\_\_\_\_

Contract Times with all approved Change Orders:

Substantial completion (days or date): \_\_\_\_\_

Ready for final payment (days or date): \_\_\_\_\_

RECOMMENDED:

By: \_\_\_\_\_

Engineer (Authorized Signature)

Date: \_\_\_\_\_

Approved by Funding Agency (if applicable):

ACCEPTED:

By: \_\_\_\_\_

Owner (Authorized Signature)

Date: \_\_\_\_\_

ACCEPTED:

By: \_\_\_\_\_

Contractor (Authorized Signature)

Date: \_\_\_\_\_

Date: \_\_\_\_\_

# Change Order

## Instructions

### A. GENERAL INFORMATION

This document was developed to provide a uniform format for handling contract changes that affect Contract Price or Contract Times. Changes that have been initiated by a Work Change Directive must be incorporated into a subsequent Change Order if they affect Price or Times.

Changes that affect Contract Price or Contract Times should be promptly covered by a Change Order. The practice of accumulating Change Orders to reduce the administrative burden may lead to unnecessary disputes.

If Milestones have been listed in the Agreement, any effect of a Change Order thereon should be addressed.

For supplemental instructions and minor changes not involving a change in the Contract Price or Contract Times, a Field Order should be used.

### B. COMPLETING THE CHANGE ORDER FORM

Engineer normally initiates the form, including a description of the changes involved and attachments based upon documents and proposals submitted by Contractor, or requests from Owner, or both.

Once Engineer has completed and signed the form, all copies should be sent to Owner or Contractor for approval, depending on whether the Change Order is a true order to the Contractor or the formalization of a negotiated agreement for a previously performed change. After approval by one contracting party, all copies should be sent to the other party for approval. Engineer should make distribution of executed copies after approval by both parties.

If a change only applies to price or to times, cross out the part of the tabulation that does not apply.

# **LIEN RELEASE**

NAME OF GENERAL CONTRACTOR:

\_\_\_\_\_

PROJECT: **Remount & Batesville Pike Guard Rail**

ENGINEER'S PROJECT NUMBER: **City Project No. 21-24**

PAY REQUEST NUMBER: \_\_\_\_\_

The undersigned Contractor certifies that: (1) all previous progress payments received from OWNER on account of Work done under the Contract referred to above have been applied to discharge in full all obligations of CONTRACTOR incurred in connection with Work covered by Prior Applications for Payment numbered 1 through \_\_\_\_\_ inclusive; (2) title to all Work, materials, labor, and equipment incorporated in said Work or otherwise listed in or covered by this Application for Payment will pass to OWNER at time of payment free and clear of all (i.e., all stored materials, subcontracted work, labor, materials, equipment, and other items incorporated into Work have been paid to date by the Contractor) liens, claims, security interest, and encumbrances; and (3) all Work covered by this Application for Payment is in accordance with the Contract Documents and not *defective* as that term is defined in Contract Documents.

If it is found that material or work has not been paid as sworn on this document, the full amount of the unpaid payment shall be withheld from the next pay estimate, and a check will be prepared by the Owner, made out jointly to the Contractor and the payee for materials or work. The check will be mailed to the payee.

Signed this \_\_\_\_\_ day of \_\_\_\_\_, 20\_\_\_\_.

Subscribed and Sworn to before me

\_\_\_\_\_

Contractor

this \_\_\_\_\_ day of \_\_\_\_\_, 20\_\_\_\_.

By \_\_\_\_\_

Notary Public

Title \_\_\_\_\_

My commission expires the \_\_\_\_\_ day of \_\_\_\_\_, 20\_\_\_\_.

# Certificate of Substantial Completion

Project:

Owner: City of North Little Rock

Owner's Contract No.:

Contract:

Engineer's Project No.:

**This [tentative] [definitive] Certificate of Substantial Completion applies to:**

- All Work under the Contract Documents:       The following specified portions of the Work:

---

---

---

---

\_\_\_\_\_  
Date of Substantial Completion

The Work to which this Certificate applies has been inspected by authorized representatives of Owner, Contractor, and Engineer, and found to be substantially complete. The Date of Substantial Completion of the Project or portion thereof designated above is hereby declared and is also the date of commencement of applicable warranties required by the Contract Documents, except as stated below.

A [tentative] [definitive] list of items to be completed or corrected is attached hereto. This list may not be all-inclusive, and the failure to include any items on such list does not alter the responsibility of the Contractor to complete all Work in accordance with the Contract Documents.

**The responsibilities between Owner and Contractor for security, operation, safety, maintenance, heat, utilities, insurance and warranties shall be as provided in the Contract Documents except as amended as follows:**

- Amended Responsibilities                       Not Amended

Owner's Amended Responsibilities:

---

---

---

Contractor's Amended Responsibilities:

---

---

---

---

The following documents are attached to and made part of this Certificate:

---

---

---

This Certificate does not constitute an acceptance of Work not in accordance with the Contract Documents nor is it a release of Contractor's obligation to complete the Work in accordance with the Contract Documents.

---

Executed by Engineer

---

Date

---

Accepted by Contractor

---

Date

---

Accepted by Owner

---

Date



**STATE OF ARKANSAS  
DEPARTMENT OF LABOR  
ARKANSAS OCCUPATIONAL SAFETY & HEALTH**

10421 WEST MARKHAM • LITTLE ROCK, AR 72205-2190

Phone: 501-682-9091 Fax: 501-682-4532 TRS: 800-285-1131

**REPORTING FORM FOR  
WORK NEAR OVERHEAD HIGH VOLTAGE POWER LINES AND  
CONDUCTORS**

**This form must be completed by any person, firm, or corporation that desires to carry on any work or activity within ten feet (10') of overhead energized electrical lines or conductors. *Arkansas Code § 11-5-307*. The ten feet clearance applies to any part of any machinery, equipment or materials, as well as any employee or person.**

Name of company or individual: \_\_\_\_\_

Address: \_\_\_\_\_ Phone Number: \_\_\_\_\_

Name & title of person filing report: \_\_\_\_\_

Date work to be performed: \_\_\_\_\_

Expected date of completion: \_\_\_\_\_

Has the operator of the electrical lines been notified? \_\_\_\_\_

---

**IMPORTANT**

*Arkansas Code § 11-5-307 also requires written notice to the owner or operator of the electrical lines. You must also make appropriate arrangements with the operator of the electrical lines **before** proceeding with any work which would violate the ten feet clearance requirement.*

*The Arkansas Department of Labor provides free training on working safely near high voltage lines.*

---

**SEND NOTICE TO:**

**Arkansas Department of Labor  
Safety Division  
10421 West Markham Street  
Little Rock, AR 72205  
(501) 682-9091  
fax: (501) 682-4532  
e-mail: [mike.watson@arkansas.gov](mailto:mike.watson@arkansas.gov)**

# Vicinity Map

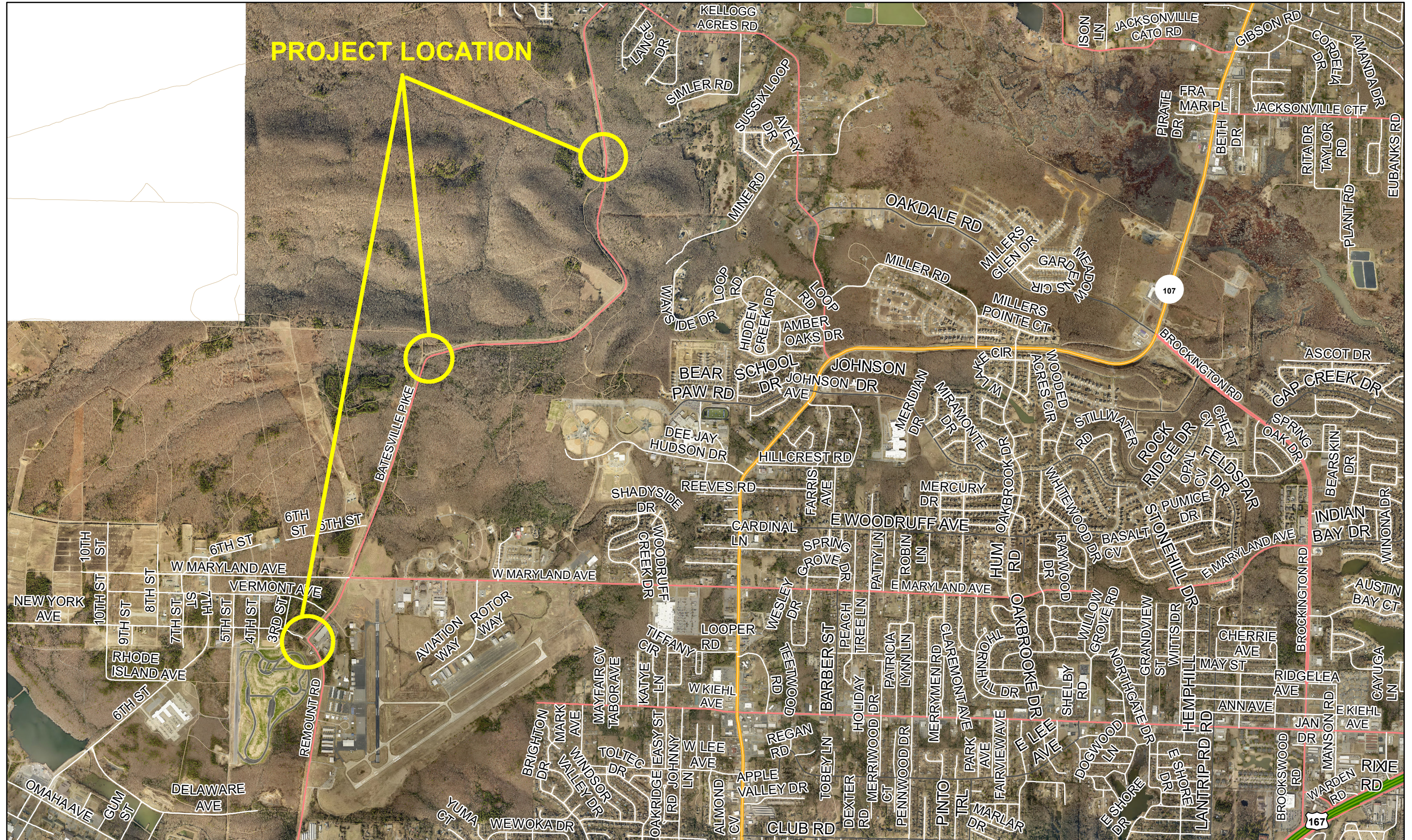

1 inch = 2,000 feet



# Site #1



Proposed 275 LF  
of Type A Guard Rail  
& 2 Terminals



1 inch = 40 feet

# Site #2



1 inch = 50 feet

# Site #3



1 inch = 200 feet

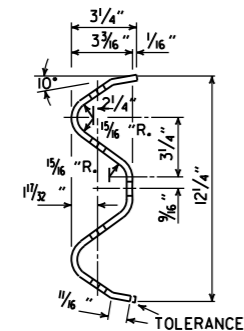
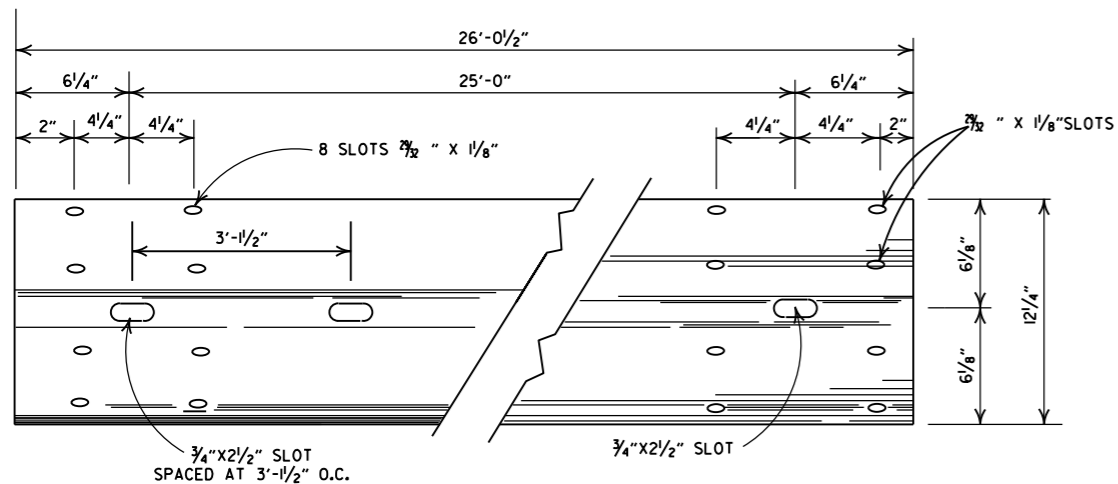

**DETAILS OF W-BEAM GUARDRAIL**

RAIL SECTION OF CLOSELY SIMILAR DIMENSIONS AND COMPARABLE STRENGTH MAY BE SUBSTITUTED IF APPROVED BY THE ENGINEER.

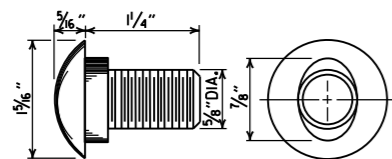

**SPLICE BOLT  
POST BOLT - SAME EXCEPT LENGTH**

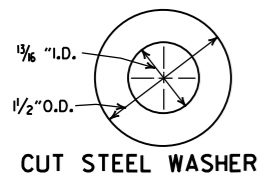

**CUT STEEL WASHER**

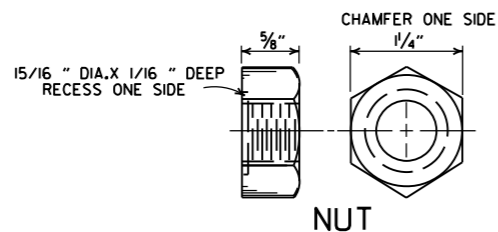

**NUT**

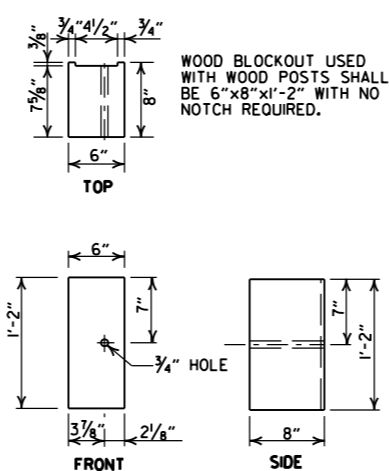

**WOOD BLOCKOUT  
(W-BEAM)**

WOOD BLOCKOUT USED WITH WOOD POSTS SHALL BE 6"x8"x1'-2" WITH NO NOTCH REQUIRED.

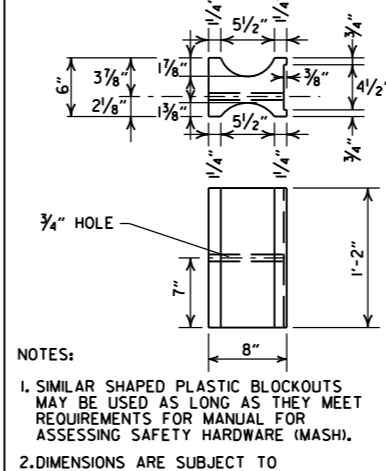

**PLASTIC BLOCKOUT  
(W-BEAM)**

NOTES:  
1. SIMILAR SHAPED PLASTIC BLOCKOUTS MAY BE USED AS LONG AS THEY MEET REQUIREMENTS FOR MANUAL FOR ASSESSING SAFETY HARDWARE (MASH).  
2. DIMENSIONS ARE SUBJECT TO MANUFACTURERS TOLERANCES.

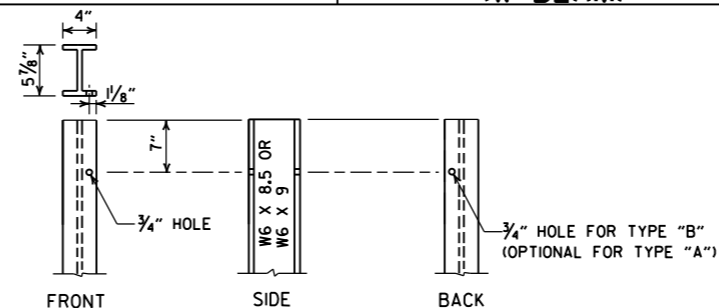

**STEEL POST**

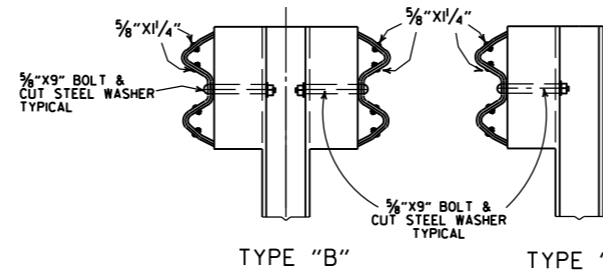

**DETAILS OF STEEL LINE POST CONNECTIONS  
(W-BEAM)**

**-GENERAL NOTES-**

ALL BOLTS SHALL BE SUFFICIENT LENGTH TO EXTEND THROUGH THE FULL THICKNESS OF THE NUT AND NO MORE THAN 3/4" BEYOND IT.

WHERE W-BEAM GUARDRAIL CONTINUES, THE INTERMEDIATE SECTIONS SHALL HAVE A POST SPACING OF 6'-3" UNLESS OTHERWISE NOTED.

W-BEAM GUARDRAIL REPRESENTING INTERMEDIATE SECTIONS WILL BE MEASURED ALONG THE ROADWAY FACE FROM CENTERLINE OF POST TO CENTERLINE OF POST.

USE W-BEAM GUARDRAIL COMPONENTS OF SAME MATERIAL FOR ENTIRE JOB. FOR EXTENSIONS OR MODIFICATION OF EXISTING GUARDRAIL, W-BEAM GUARDRAIL COMPONENTS OF THE SAME TYPE AS THOSE EXISTING SHALL BE USED.

ANY BACKFILLING UNDER OR AROUND POST SHALL BE DAMP SAND THOROUGHLY TAMPED IN PLACE.

WOOD POSTS & WOOD BLOCKS SHALL BE EITHER DENSE NO. 1 STRUCTURAL OR BETTER 9.7f (1400 f) OR NO. 1 1350 f SOUTHERN PINE.

CONTRACTOR SHALL HAVE THE OPTION OF USING WOOD BLOCKOUTS FOR W-BEAM GUARDRAIL OR PLASTIC BLOCKOUTS, AS LONG AS BLOCKOUT USED MEETS REQUIREMENTS FOR MANUAL FOR ASSESSING SAFETY HARDWARE (MASH) FOR W-BEAM GUARDRAIL.

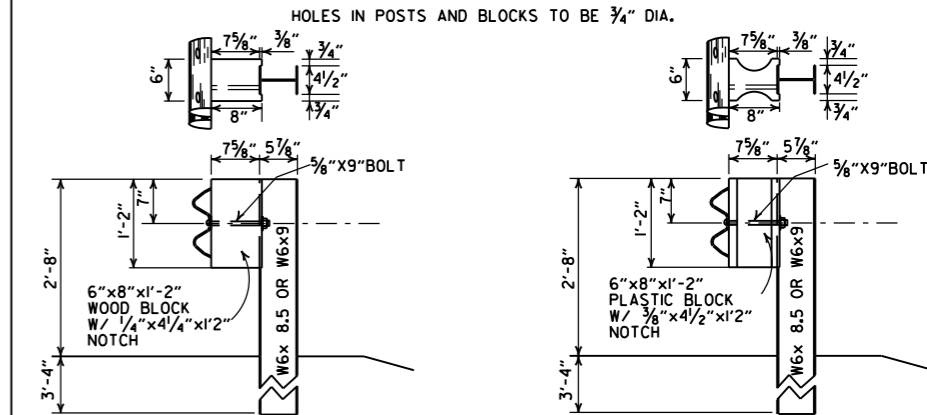

**WOOD BLOCKOUT CONNECTIONS**

**DETAILS OF STEEL LINE POST CONNECTIONS  
(W-BEAM)**

**PLASTIC BLOCKOUT CONNECTIONS**

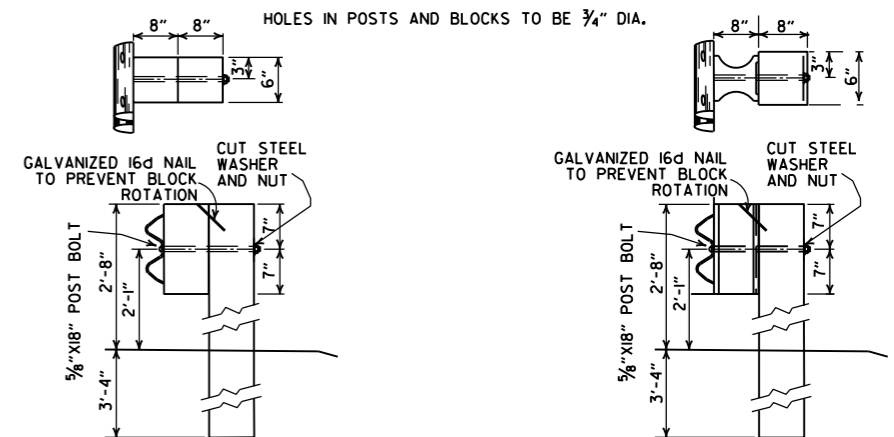

POSTS AND BLOCKS TO BE ROUGH SAWN 6"x8" WITH A TOLERANCE OF + OR - 1/4".

**WOOD BLOCKOUT CONNECTIONS**

**DETAILS OF WOOD LINE POST CONNECTIONS  
(W-BEAM)**

**PLASTIC BLOCKOUT CONNECTIONS**

11-07-19	RENUMBERED AND RENAMED	
11-16-17	REVISED GENERAL NOTES AND RAISED GUARDRAIL HEIGHT 3"	
07-14-10	RAISED HEIGHT OF GUARDRAIL 1"	
10-15-09	ADDED REFERENCE TO MASH	
04-10-03	REVISED GENERAL NOTES	
08-22-02	REVISED DIMENSION ON WOOD & PLASTIC BLOCKOUT CONNECTIONS & STEEL POST	
11-16-01	REVISED WOOD BLOCKOUT & DETAILS OF WOOD LINE POST CONNECTIONS	
03-30-00	REMOVED GUARDRAIL AT BRIDGE ENDS	
01-12-00	ADDED PLASTIC BLOCKOUT	
08-12-98	REV. BLOCKOUTS TO WOOD, DELETED CONC. POST & REV. GENERAL NOTE, DELETED DET. OF GUARDRAIL REPLACE. BEHIND CURB & DET. OF POST PLACE. IN SOLID ROCK, & ADDED DETAILS OF STEEL LINE POST CONN. REMOVED BACK-UP PLATE, REVISED HOLES IN STEEL POLES	
04-03-97	REMOVED "LAP IN DIRECTION OF TRAFFIC" NOTE & PLACED ARROWS ON WASHERS	
10-18-96	REVISED WOOD POST NOTE	
06-02-94	ADDED ALT. STEEL POST SIZE	
08-05-93	REVISED STEEL POST SIZE	8-5-93
10-01-92	REDRAWN & REVISED	10-1-92
08-15-91	REVISED WASHER NOTE	8-15-91
08-02-90	REV. GEN. NOTE & DEPTH OF ANC. POST IN ROCK	8-2-90
07-15-88	REVISED SECTION 3 & GENERAL NOTES	
03-04-88	REV. ANCHOR POST, ELEV. NOTES & POST IN ROCK	780-3-4-88
10-30-87	REVISED WOOD LINE POST DETAIL	546-10-30-87
10-09-87	REDRAWN & REVISED	802-10-9-87
DATE	REVISION	FILMED

ARKANSAS STATE HIGHWAY COMMISSION

**GUARDRAIL DETAILS**

**STANDARD DRAWING GR-6**

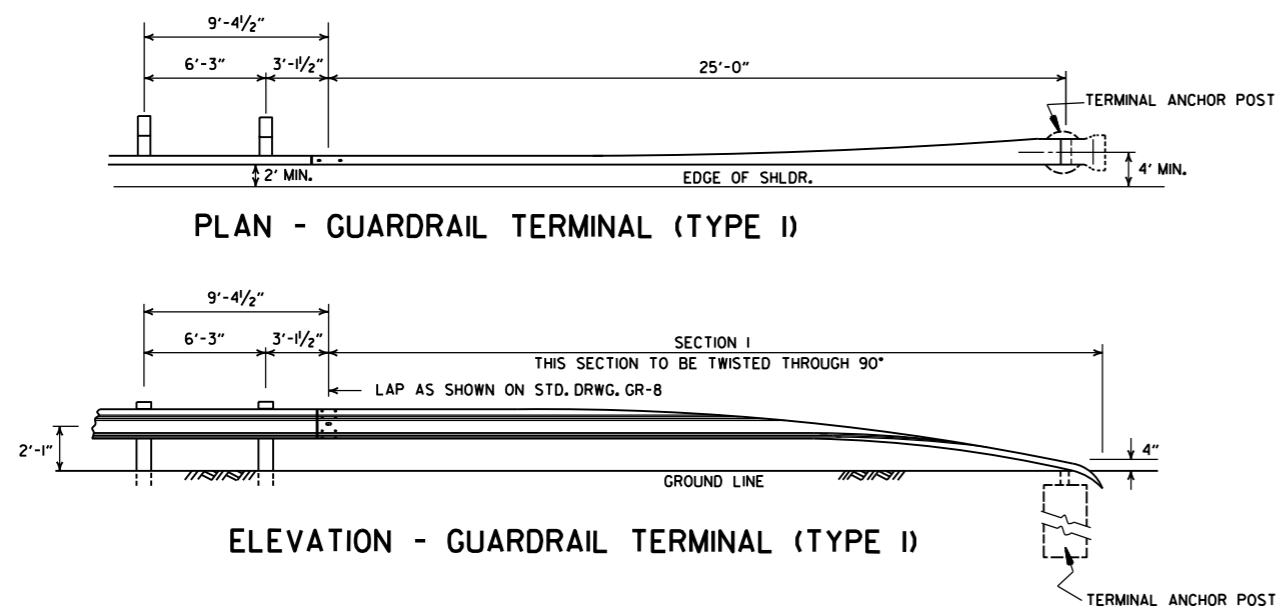

PLAN - GUARDRAIL TERMINAL (TYPE I)

ELEVATION - GUARDRAIL TERMINAL (TYPE I)

NOTE:  
SECTIONS 1 AND 2 OF GUARDRAIL TERMINAL  
SHALL BE PAID FOR AT THE PRICE BID PER  
LINEAR FOOT OF THE TYPE OF GUARDRAIL SPECIFIED.

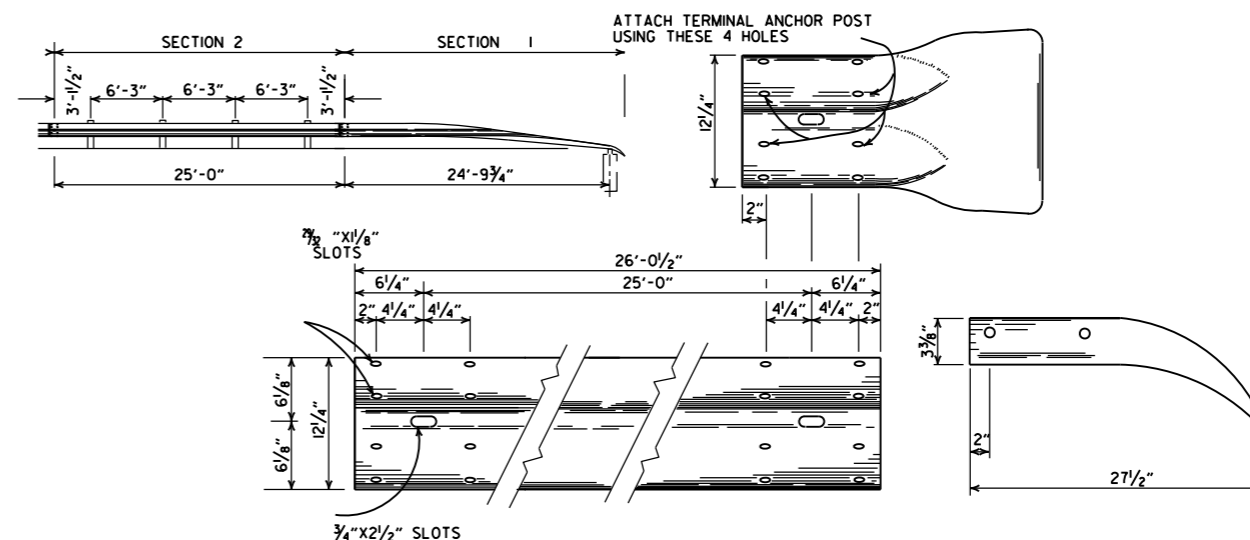

SECTION 1

TERMINAL SECTION

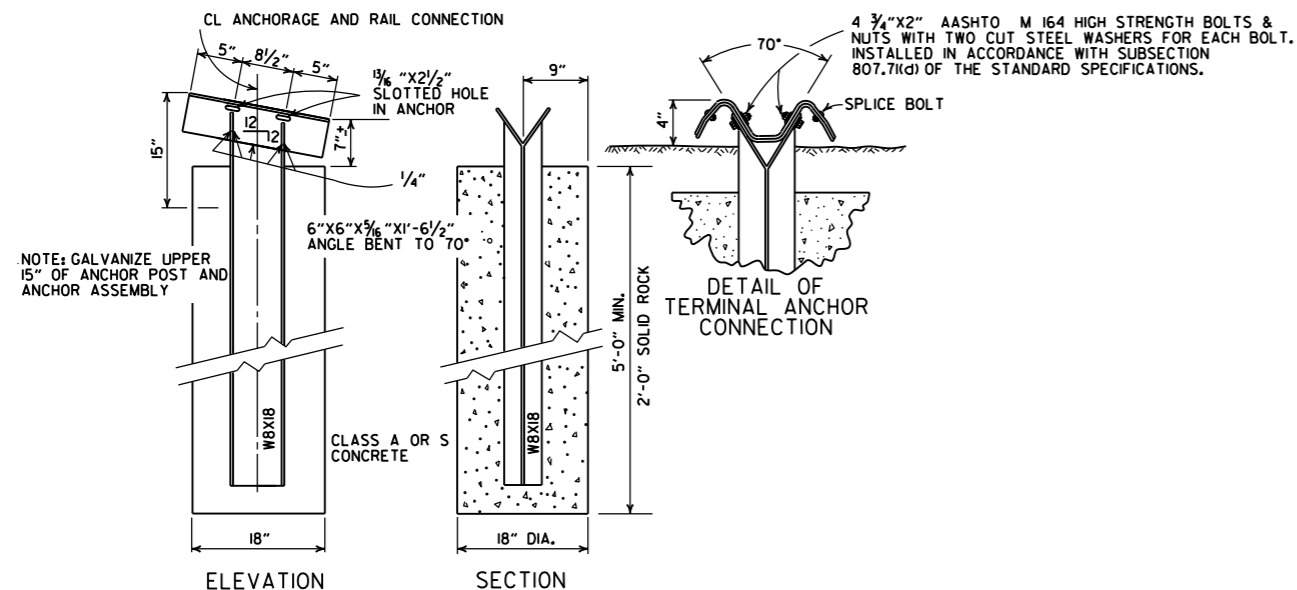

ELEVATION

SECTION

DETAIL OF  
TERMINAL ANCHOR  
CONNECTION

NOTE: RAIL MEMBERS MAY BE BOLTED TO ANGLE AT TERMINAL ANCHOR AND THE TWO ASSEMBLIES POSITIONED TO PROPER ALIGNMENT PRIOR TO PLACING CONCRETE AROUND 8 W/ 17 POST IF CONTRACTOR SO DESIRES.

DETAIL OF TERMINAL ANCHOR POST (TYPE I)

11-07-19	RENAMED & REVISED REFERENCE.		ARKANSAS STATE HIGHWAY COMMISSION
11-16-17	REVISED GUARDRAIL HEIGHT AND LOCATION OF POSTS		GUARDRAIL DETAILS
07-14-10	RAISED HEIGHT OF GUARDRAIL 1"		
06-26-97	REVISED LAP NOTE		STANDARD DRAWING GRT-1
10-18-96	REVISED ASTM REF. TO AASHTO		
11-03-94	DIMENSION TERMINAL DETAIL		
11-11-92	ADDED NOTE FOR PAYMENT	11-11-92	
10-01-92	DRAWN & ISSUED	10-1-92	
DATE	REVISION	FILMED	